



CALIFORNIA

High-Speed Rail Authority

RFP No.: HSR25-89

Request for Proposals for Track and Systems Construction Contract

Instructions to Proposers, Forms, and Certifications

RFP No.: HSR25-89 TSCC ADDENDUM 8 04/01/2026

Revision(s)	Date	Description
0	11/26/2025	Initial Release
1	12/16/2025	Addendum 1
2	1/27/2026	Addendum 2
3	1/30/2026	Addendum 3
4	2/27/2026	Addendum 4
5	3/10/2026	Addendum 5
6	3/20/2026	Addendum 6
7	3/26/2026	Addendum 7
8	4/1/2026	Addendum 8

Table of Contents

INTRODUCTION 1

1 GENERAL BACKGROUND 1

2 PURPOSE AND OVERVIEW OF RFP 2

 2.1 Nature of the Proposed Work 5

 2.2 Description of the Work 7

 2.3 Options Work Authorizations 7

 2.4 Track & Systems Construction Contract RFP 8

 2.5 Reference Materials..... 8

 2.6 Definitions.....10

 2.7 Acronyms15

INSTRUCTIONS TO PROPOSERS.....18

3 PROCUREMENT SCHEDULE AND PROCESS18

 3.1 Authority’s Designated Point of Contact.....20

 3.2 Addenda to RFP20

 3.3 Non-Commitment of Authority.....20

 3.4 Property Rights.....21

 3.5 Non-Exclusiveness of Subcontractors.....21

 3.6 Improper Communications and Contacts21

 3.7 Organizational Conflicts of Interest23

 3.7.1 Organizational Conflicts of Interest for Future Contracts26

 3.8 Confidentiality and Proposer Work Product.....26

 3.9 Executive Order N-6-22 – Russia Sanctions27

 3.10 Equal Employment Opportunity and Nondiscrimination27

 3.11 Labor Compliance.....28

 3.12 The California Environmental Quality Act.....28

 3.13 Liability, Insurance, and Performance Security28

 3.14 Generative Artificial Intelligence Disclosure Notification Requirements29

 3.15 Small Business Program and Small Business Performance Plan29

 3.16 Small Business Communication Plan.....31

4 SUBMITTAL OF THE PROPOSAL31

 4.1 Proposal Submittal Information31

 4.2 Late Submittals32

 4.3 Modification or Withdrawal of Proposals32

5 PROJECT STATUS.....33

 5.1 Environmental Analysis33

 5.2 Governmental Approvals34

 5.3 Right-of-Way.....34

 5.4 Railroads34

RFP No.: HSR25-89 TSCC ADDENDUM 8 04/01/2026



5.5	Reserved	34
5.6	Federal Requirements	34
5.7	Buy America Requirements	35
5.7.1	Overview	35
5.7.2	Part I: Buy America Certification	36
5.7.2.1	Buy America Certificate	36
5.7.2.2	Written Justification for Waiver.....	37
5.7.3	Part II – Buy America Audits	38
5.8	Pre-Proposal Submittals and Meetings.....	38
5.8.1	Notice of Intent to Propose	38
5.8.2	One-on-One Meetings	38
5.8.3	Nondisclosure Agreement for Confidential Reference Materials	39
5.8.4	ATC Process	39
	PROPOSALS.....	40
6	PROPOSAL SUBMITTAL REQUIREMENTS	40
6.1	Compliant Proposal	40
6.2	Format Requirements	40
6.3	Contents and Organization	41
6.3.1	Digital Submission Requirements	41
6.4	Volume 1A – Administrative Submittals	42
6.5	Volume 1B – Financial Information	49
6.6	Volume 2 – Executive Summary and Technical Proposal	51
6.6.1	Executive Summary.....	52
6.6.2	Technical Proposal	53
6.7	Volume 3 – Price Proposal	64
6.8	Escrowed Proposal Documentation	67
6.9	Stipend Payment	68
7	EVALUATION AND NEGOTIATION	69
7.1	Proposal Review.....	69
7.2	Proposal	69
7.3	Proposer Minimum Qualifications	69
7.4	Price Scoring	70
7.5	RFP Revisions and BAFOs.....	70
7.6	Final Scoring.....	71
7.7	Notice of Proposed Award	71
7.8	Contract Negotiation Process	71
7.9	No Contract Until Signed and Approved	71
7.10	Debriefings	71
7.11	Confidentiality	72
8	PROTEST PROCEDURES	72
8.1	Applicability.....	72



8.2 Required Early Communication for Certain Protests72
 8.3 Deadlines for Protests73
 8.4 Content of Protest.....73
 8.5 Filing of Protest.....74
 8.6 Comments from Other Proposers74
 8.7 Authority Response to a Protest74
 8.8 Burden of Proof74
 8.9 Decision on Protest.....74
 8.10 Limitation on the Authority’s Liability75

List of Tables

Table 1: RFP Schedule18
 Table 2: Firms Subject to Proposer Ex Parte Communications Prohibitions During this Procurement23

List of Figures

Figure 1: RFP Section Map 6

List of Attachments

- Attachment A: Minimum Qualifications Checklist
- Attachment B: Criteria for Awarding Points for the Proposal
- Attachment C: Reference Materials
- Attachment D: Bid Tab Description

List of Forms and Certifications

Forms

- Form A: Transmittal Letter**
- Form B: Identification of Proposer’s RFP/Proposal Manager**
- Form C: Information about Proposer, Equity Members, Lead Contractor, and Guarantors**



Form D:	Identification of Proposer Team Members
Form E:	Key Personnel Matrix
Form F:	Schedule of Subcontractor(s)
Form G:	Past Performance Certification
Form H:	Organizational Conflicts of Interest Disclosure Statement
Form I:	Verification, Validation, and Self-Certification Commitment
Form J2:	Price Proposal Summary
Form K:	Past Projects
Form L:	Project Owner References
Form M:	Key Personnel References
Form N:	Disabled Veteran Business Enterprise Declaration
Form O:	Proposal Checklist
Form P:	Proposer Nondisclosure Agreement
Form Q:	Stipend Agreement
Form R:	Proposer Nondisclosure Agreement (Technical Drawings and Reports)
Form S:	Past Performance Questionnaire

Certifications

Cert. 1:	Debarment, Suspension, Ineligibility, and Voluntary Exclusion Certification
Cert. 2:	Non-Collusion Affidavit
Cert. 3:	Organizational Conflicts of Interest Affidavit
Cert. 4:	Equal Employment Opportunity Certification
Cert. 5:	Non-Discrimination Certification
Cert. 6:	Certification Regarding Lobbying
Cert. 7:	Drug Free Workplace Program Certification
Cert. 8:	Buy America Compliance or Non-Compliance Certifications
Cert. 9:	Iran Contracting Certification
Cert. 10:	Darfur Contracting Act Certification
Cert. 11:	Certification Regarding Miscellaneous State Requirements



- Cert. 12: Proposer’s Project Small Business Goal Commitment Affidavit**
- Cert. 13: California Civil Rights Laws Certification**
- Cert. 14: CCC 04/2017 and STD 204**
- Cert. 15: Generative Artificial Intelligence Disclosure**
- Cert. 16: Escrowed Proposal Documents Certification**

RFP No.: HSR25-89 TSCC ADDENDUM 8 04/01/2026



INTRODUCTION

1 General Background

The California High-Speed Rail Authority (Authority) is responsible for planning, designing, building, and operating the first high-speed rail system in the nation. California high-speed rail will connect the mega-regions of the state, contribute to economic development and a cleaner environment, create jobs, and preserve agricultural and protected lands.

The Authority may enter into contracts with private and public entities for the design, construction, and operation of high-speed rail trains including all tasks and segments thereof pursuant to California Public Utilities Code section 185036.

This Project is funded with State of California and federal funds, including, but not limited to, funds provided by the Federal Railroad Administration (FRA) and funds made available through the various federal funding grant programs and, therefore, requires certain federal provisions in each contract. The Authority is the FRA-designated recipient for federal transportation funds and receives these funds on a reimbursement basis, which could lead to requirements changing over time to substantiate the Work performed under this contract.

Capitalized terms within this document are defined in Section 2.6 of this RFP.

Any services or Work performed must be consistent and/or compliant with the conditions set forth within the following:

- [California State Budget Act 2012-13, SB1029](#) (Chapter 152, Statutes of 2012)
- California State Budget Act of 2022, [SB198](#) and [AB180](#) (amending the Budget Act of 2021).
- [2024 Business Plan - California High Speed Rail](#)
- [California High-Speed Rail Program 2025 Project Update Report and 2025 Supplemental Project Update Report](#).
- U.S. Department of Transportation FRA [Grant/Cooperative Agreements](#) FR-HSR-0009-10-01-07 including subsequent amendments, FR-HSR 0118-12 including subsequent amendments, and 69A36524521070FSPCA (FSP Grant).
- The California High-Speed Rail Business Small Business Program Plan for Small Business Participation, [Policy & Program Plan - California High Speed Rail](#).



2 Purpose and Overview of RFP

The following list provides a general overview of information related to the subject of this Request for Proposals (RFP).

1. The Authority is issuing this RFP to receive Proposals from qualified firms (Proposers) for the delivery of the Authority's Track and Systems Construction Contract (TSCC). The TSCC scope of work will include construction work for track and overhead contact system (OCS) on the 171-mile Early Operating Segment of the California High-Speed Rail System, and design and construction for high-speed rail systems, including traction power, train control, telecommunications, and supervisory control and data acquisition (SCADA) systems. The scope of work will also include testing and commissioning for the Work. The Work will be delivered using a hybrid delivery model that will incorporate managing cost and schedule, identifying and mitigating risk, partnering, collaboration, in-depth communication, motivation for innovation, and progressive project development of construction packages. The TSCC Contractor will work collaboratively with the Authority, the Authority's Track/OCS Design Services consultant, stakeholders, and other Interfacing Contractors to deliver the work. Proposers are requested to submit to the Authority a Proposal to deliver the Work, including all work required for the performance of a contract resulting from this RFP (Contract). The form of Contract is included as part of this RFP.
2. The Authority will use a one-step procurement process to select a Contractor to deliver the Work. This RFP is issued to solicit information from Proposers in the form of a Proposal. The Technical Proposal and Price Proposal will be evaluated to determine which Proposer provides the apparent best value to successfully deliver the Work.
3. As further described in this RFP and the Contract, the Work is intended to be delivered in multiple Packages, authorized through Notices to Proceed (NTP) as outlined in Section 2.2, below.
4. The Work will be divided into separate Packages that will each have a separate cost. Each Package will be authorized through a Notice to Proceed and amendment to the Contract that incorporates Package specific details and scope.
5. This procurement will be evaluated based on the combined Technical Proposal and Price Proposal scores of Proposers meeting the minimum requirements of Sections 6 and 7. Responsive Proposals submitted in response to this RFP will be evaluated with the intent of awarding a contract to the Proposer with the highest score.



6. The selected Proposer may work with the Federal Railroad Administration (FRA), Surface Transportation Board, California Public Works Board, California Department of Transportation (Caltrans), California Department of General Services (DGS), other partnering agencies, the Interfacing Contractors, and other Authority contractor(s)/consultant(s).
7. The term of the Contract resulting from this RFP is anticipated to begin upon Contract execution and extend through Final Acceptance of all Work, with certain obligations, such as warranty obligations, extending beyond Final Acceptance.
8. The Contract will include options for the following work, which may be exercised at the Authority's sole discretion:
 - a. Design and/or construction of Maintenance of Way Facility, Operations Control Center, Trainset Certification Facility, or other facilities to the extent that they are not included in the Scope of Work of the Contract;
 - b. Maintenance of high-speed rail systems assets after final acceptance;
 - c. Construction, long lead items, testing, and commissioning for track, OCS, traction power, train control, telecommunications systems, and SCADA systems for the Merced Extension;
 - d. Construction, long lead items, testing, and commissioning for track, OCS, traction power, train control, telecommunications systems, and SCADA systems for the Bakersfield Extension; and/or
 - e. Construction, supply long lead items, testing, and commissioning for track, OCS, traction power, train control, and communications systems for the High Desert Corridor.
9. The not-to-exceed dollar value for the Contract is \$3.5 billion. Executing a Contract is not a guarantee of Work; the actual amount of Work requested by the Authority under a Contract resulting from this RFP may be less. Funding amounts are subject to change.
10. The Contract will allow a novation by the Authority to a private developer that would develop one or more public-private partnership project(s) to deliver portions of the California High-Speed Rail System, should the Authority establish such an arrangement.
11. Any Work to be provided by the selected Proposer shall only be performed pursuant to a NTP that provides a detailed description of the Work to be



- performed under the applicable Package, the time for the Work to be performed, and final mutually agreed price for the Package.
12. The services described herein are not exclusive, and the Authority reserves the right to enter into other contracts/agreements covering the same or similar services, or to perform the same or similar services itself or through its agents.
 13. The evaluation/selection of Proposals will be based on the factors/criteria contained in this RFP including all Attachments.
 14. This RFP incorporates by reference the Authority's High-Speed Rail Small Business Program Plan (HSR SB Program Plan), which, among other requirements, establishes a 25 percent Small Business (SB) utilization goal, inclusive of a 3 percent carve out for microbusiness (applied to state funded Contract value) and 3 percent Disabled Veteran Business Enterprises (DVBE) goals (applied to entire Contract value). Further details about the Authority's small business goals and specific requirements under its HSR SB Program Plan may be found at the website for the HSR SB [Policy & Program Plan - California High Speed Rail](#).
 15. For each portion of Work, if applicable and as required by the Contract, the Contractor may be required to propose and/or follow performance targets and measures suitable for measuring performance towards the Authority's performance objectives.
 16. Negotiations, as set forth herein, shall be held with the top-ranked Proposer.
 17. This RFP will be available in electronic format on the California State Contracts Register website, [Cal eProcure](#).
 18. All questions regarding this RFP must be submitted in writing to the email address of the Authority's Designated Point of Contact in Section 3.1 of this RFP by the date and time listed in Section 3.0, Table 1, Key RFP Dates. All such questions should use the subject line: HSR25-89 Request for Proposals for the Track and Systems Construction Contract. Responses to questions submitted will be posted on the California State Contracts Register for the benefit of all Proposers. Responses to questions do not become part of the TSCC Agreement unless incorporated into the TSCC Agreement by addendum.
 19. Interested Proposers will be required to submit a Notice of Intent to Propose as a prerequisite to meeting with the Authority. Failure to submit a Notice of Intent to Propose, will not preclude the opportunity for the submission of an



- RFP, but a site visit and a one-on-one meeting time opportunities, could be limited or not offered, due to limited availability.
20. The Authority will conduct exclusive one-day Central Valley site visits, only to parties who have filed the Notice of Intent to Propose (as defined herein) The site visit will focus on the geographic areas of Construction Package 4 and the Southern Railhead. Each one-day site visit will be exclusive with only One (1) Prime Proposer/Team and limited to no more the six attendees in total, and along with the Authority's representatives the group will be provided up to six hours of site visit time for a general overview of NTP 1 and NTP 2. A Proposer who intends to attend the site visit will be asked to request the site visit by the date listed in Table 1, Key RFP Dates.
21. The Authority intends to conduct one-on-one meetings with interested Proposers that submit a Notice of Intent to Propose. Information regarding the one-on-one meetings is included in Section 5.8.2 of this RFP. Anticipated dates for one-on-one meetings are included in Section 3.0, Table 1, Key RFP Dates. One-on-one meetings are not mandatory.
22. Some reference materials for this RFP are only available upon delivering a signed nondisclosure agreement to the Authority. The nondisclosure form is available as Form P to this RFP, and information regarding reference materials is available in Section 2.5 of this RFP.

2.1 Nature of the Proposed Work

The Work will be delivered utilizing a hybrid delivery method that incorporates collaborative partnering, identifying and mitigating risks, in-depth communication, motivation for innovation, and progressive project development toward pricing for construction using Work Packages and open-book pricing methods.

The Work includes responsibility for the Contractor to proactively engage with Interfacing Contractors (particularly, the Track and OCS Design Services consultant), and the Authority to ensure the successful and consistent identification and integration of all technical and non-technical interfaces across the Interfacing Contracts. The Contractor shall be responsible for technical and programmatic integration of the Work.

A map of the area to which the Work will relate is included below as Figure 1.



Figure 1: RFP Section Map

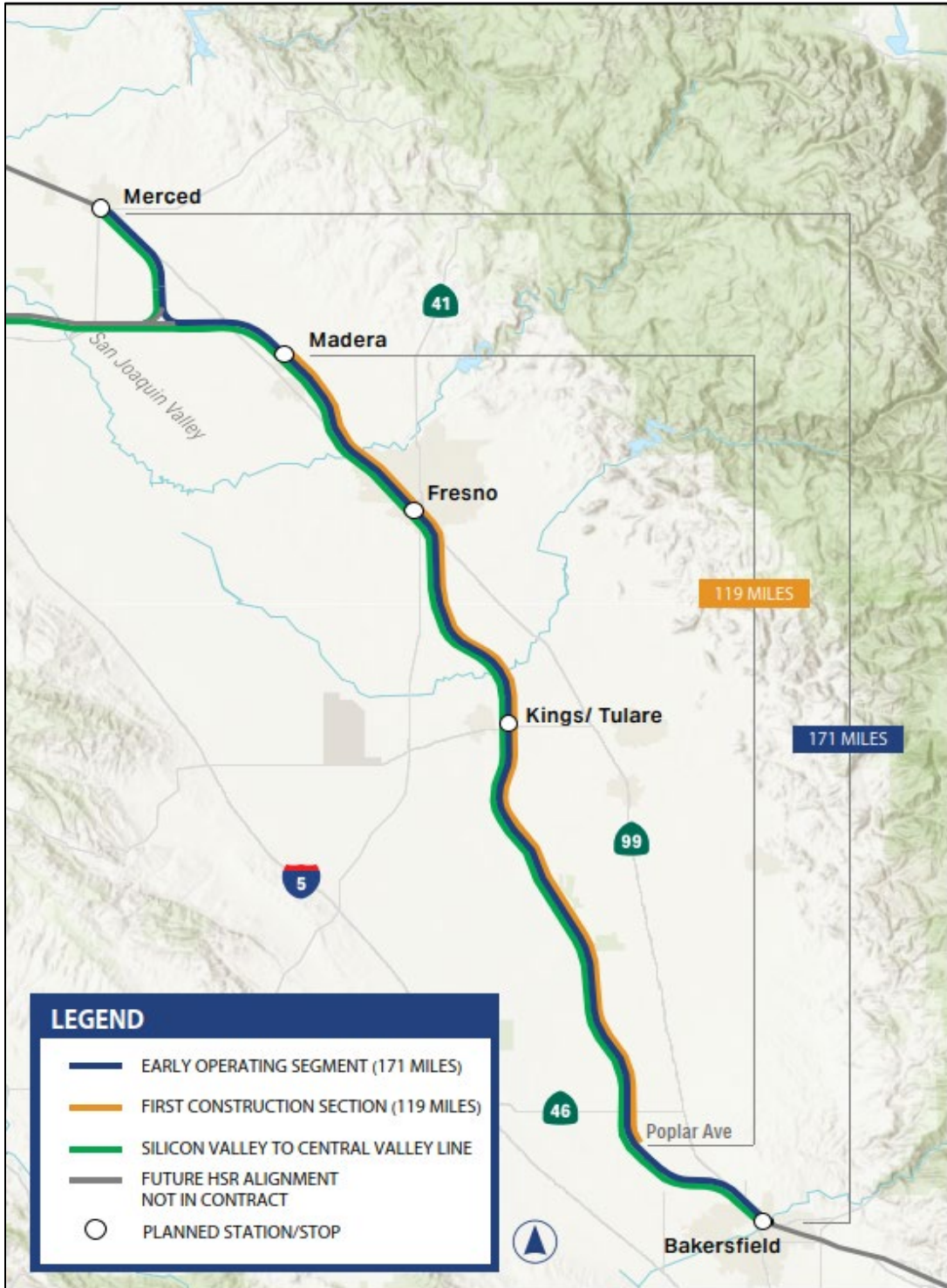

RFP No.: HSR25-89 TSCC ADDENDUM 8 04/01/2026



2.2 Description of the Work

The Contractor will be responsible for the following Work under the Contract for the 119-mile First Construction Section:

- (a) Construction Work for track, overhead contact system (OCS), and related civil works;
- (b) Fresno County railhead development;
- (c) Design and construction for high-speed rail systems, including traction power, train control, and communications;
- (d) Systems integration;
- (e) Safety certification; and
- (f) Testing and commissioning of the high-speed rail system.

The Contractor will also be responsible for the following Work under the Contract for the Merced Extension and Bakersfield Extension:

- (g) Construction Work for track, OCS, and related civil works;
- (h) Design and construction for high-speed rail systems, including traction power, train control, and communications systems;
- (i) Systems integration;
- (j) Safety certification; and
- (k) Testing and commissioning of the high-speed rail system.

Planned sequencing of Notices to Proceed (NTP) for Packages is provided in section 1.1.6 of Schedule 16 to the TSCC Agreement. Final packaging and sequencing may be revised during the term of the Contract to maintain the Project schedule.

The Authority presently anticipates completion of construction, testing, and commissioning for the EOS to allow the start of revenue service by January 1, 2032.

2.3 Options Work Authorizations

The Contract will include options for the following work, which may be exercised at the Authority's discretion:

- Design and/or construction of Maintenance of Way Facility, Operations Control Center, Trainset Certification Facility, or other facilities to the extent they are not included in the scope above;



- Maintenance of high-speed rail systems assets after testing and commissioning and/or system certification;
- Construction, long lead items, testing, and commissioning for track, OCS, traction power, train control, telecommunications systems, and SCADA systems for the Merced Extension;
- Construction, long lead items, testing, and commissioning for track, OCS, traction power, train control, telecommunications systems, and SCADA systems for the Bakersfield Extension; and/or
- Construction, long lead items, testing, and commissioning for track, OCS, traction power, train control and communications systems, for the High Desert Corridor.

Pricing for any option(s) exercised would be developed using the pricing process established in the Contract and an NTP would be issued prior to the start of any option work.

2.4 Track & Systems Construction Contract RFP

The RFP documents are organized as follows:

- a. Instructions to Proposers
- b. TSCC Agreement
- c. Schedules to the TSCC Agreement: provided as four separate documents:
 - a. Schedules 1 through 4, inclusive
 - b. Schedule 5
 - c. Schedules 6 through 8, inclusive
 - d. Schedules 9 through 44, inclusive
- d. Reference Materials
- e. Confidential Reference Materials

The Instructions to Proposers (ITP) and Reference Materials are not Contract documents. The ITP provides instructions to be followed by Proposers in their responses to this RFP.

2.5 Reference Materials

- a. The Reference Materials are not Contract documents. The Reference Materials are included in the RFP for the purpose of providing information to



Proposers that is in the Authority's possession. The Authority has not determined whether the Reference Materials are accurate, complete or pertinent, or of any value to the Proposers. The Authority makes no representation, warranty, or guarantee as to the accuracy, completeness, pertinence or fitness of the Reference Materials. The Authority takes no responsibility for the Reference Materials and shall not be responsible for any conclusions drawn therefrom, except to the extent the Contract documents expressly allow the Contractor to rely on such documents.

- b. The Reference Materials are organized into two categories. Publicly available Reference Materials are included in the California State Contract Register. Confidential Reference Materials are only available upon request to Proposers that have completed the procedures in Section 2.5(d) of this RFP, below.

RM.10 Environmental Documents are available via Box at <https://hsra.box.com/v/HSR2589TSCCRM10EnviroDocs>.

- c. The Reference Materials are organized as provided in Attachment C to this ITP.
- d. Confidential Reference Materials are only available upon execution of the nondisclosure agreements in Form P (SNCF) and Form R (Technical Drawings and Reports) of this RFP. This Form shall be executed by each individual representative of the Proposer who will have access to the Confidential Reference Materials.
 - i. Proposers shall send a fully executed Form P and Form R for each individual requesting access by email to the Authority point of contact listed in Section 3.1.
 - ii. Approved individuals will be given view access to the secure Box folders containing Confidential Reference Materials. Access to these folders will expire at the conclusion of the procurement and Proposers will be required to destroy any downloaded Confidential Reference Materials.
- e. The California High Speed Rail Authority is licensed under SNCF America for the use of the S220 TSI catenary system developed by SNCF RESEAU, for high-speed rail line projects at 354 km/hour (or 220 miles/hour), the system is certified according to the norms and standards applicable in the European Union and compliant with the Technical Specification for Energy Interoperability. As a licensed owner of the S220 OCS design, the Authority is expected to only use the OCS design information within the strict scope and needs of the Project and limit distribution only to Third Parties that need to know, due to their duties related to the implementation of the Project.



2.6 Definitions

Whenever used in this RFP, the following terms have the definitions indicated below. Additional defined terms are included in the General Provisions.

Affiliate: (a) Any Person that, directly or indirectly through one or more intermediaries, controls, or is controlled by, or is under common control with, Contractor or any of its members, partners or shareholders holding a 10 percent or greater interest in Contractor; (b) Any Person for which 10 percent or more of the equity interest in such Person is held directly or indirectly, beneficially or of record by: (i) Contractor; (ii) Any of Contractor's members, partners or 10 percent or greater shareholders; or (iii) Any Affiliate of Contractor under part (a) of this definition; and/or (c) Subcontractor affiliates determined using the definition in "a" and "b" above, but substituting the term "Subcontractor" for "Contractor." For the purposes of this definition, the term "control" means the possession, directly or indirectly, of the power to cause the direction of the management of a Person, whether through voting securities, by contract, family relationship or otherwise.

Affiliated Subcontractor: A Subcontractor that is an Affiliate of the Contractor unless the Contractor demonstrates to the reasonable satisfaction of the Authority that the Affiliate operates as an independent entity with a separate profit center and separate Home Office Overhead from the Contractor and the Subcontract with such Affiliate includes terms and conditions no less favorable than those that Contractor could reasonably obtain in an arms' length, competitively procured transaction with an unaffiliated Subcontractor.

Agreement: See definition of "Contract" below.

Apparent Best Value Proposer: The Proposer who submits the Proposal that receives the highest Total Proposal Score.

Authority: The California High-Speed Rail Authority, which may include the Authority's authorized representatives.

Authority Board: The California High-Speed Rail Authority Board of Directors.

Authority's Designated Point of Contact: The representative of the Authority identified in Section 3.1.

Bakersfield Extension: The southern extension of the Project included in the approved 2018 and 2019 Fresno to Bakersfield Environmental Documents spanning 18.48 miles, beginning at the southern limit of high-speed rail Construction Package 4 at Poplar Avenue in the City of Shafter and ending at the Bakersfield high-speed rail station at F Street. Is sometimes referred to in other documents as the Locally Generated Alternative (LGA).



Business Day: Monday through Friday, except for federal or State of California holidays, between the hours of 8:00 a.m. and 5:00 p.m., Pacific Time. Lists of federal and State of California holidays can be found at the [U.S. Office of Personnel Management](#) and [California Department of Human Resources](#) websites, respectively.

Commercially Useful Function: The Authority will uniformly apply best practices standards in collective consideration of Commercially Useful Function (CUF) standards set forth by 49 C.F.R. Part 26.55 (c)-(d), Government Code section 14837, California Code of Regulations title 2 section 1896.4(h), and Military and Veterans Code section 999(b)(5). A Small Business (SB), Small Business for the Purpose of Public Works (SB-PW), Disabled Veteran Business Enterprise (DVBE), or Microbusiness (MB) is deemed to perform a CUF if the business meets applicable CUF standards as required by law and the State of California (see the California Department of General Services (DGS) [Commercially Useful Function for Certified Firms webpage](#) for more information). A Disadvantaged Business Enterprise (DBE) is deemed to perform a CUF if the business meets the CUF standards at 49 C.F.R. Part 26.55 (c)-(d).

Construction Package 1: The portion of the System's first construction segment currently bounded by Avenue 19 in the County of Madera to the north, and by East American Avenue in the County of Fresno to the south.

Construction Package 2-3: The portion of the System's first construction segment currently bounded by East American Avenue in the County of Fresno to the north, and a point approximately one mile north of the Tulare/Kern County line in the County of Tulare to the south.

Construction Package 4: The portion of the System's first construction section currently bounded by a point approximately one mile north of the Tulare/Kern County line in the County of Tulare to the north, and Poplar Avenue in the County of Kern to the south.

Contract: The written agreement between the Authority and the successful Proposer (Contractor) executed as a result of this procurement. Also referred to as Agreement or TSCC Agreement.

Contractor: The successful Proposer that executes the Contract with the Authority as a result of this RFP.

Day or day: Calendar Day, unless otherwise noted.

Disabled Veteran Business Enterprise: A for-profit business concern that meets the certification requirements set forth in California Military and Veterans Code section 999(b)(7), including, but not limited to, at least 51 percent



ownership by a veteran of the United States Military who has at least a 10 percent service-connected disability. To be counted towards meeting the goals of the SB Program, a Disabled Veteran Business Enterprise must: (1) Be certified by DGS' Office of Small Business and Disabled Veteran Business Enterprise Services, and (2) Perform a CUF, as defined herein, in providing services or goods that contribute to the fulfillment of the contract requirements for this procurement.

Disadvantaged Business Enterprise: A for-profit business concern that meets the requirements of Title 49, Part 26.61 through 26.73 inclusive of the Code of Federal Regulations, including, but not limited to, at least 51 percent owned by individuals who are both socially and economically disadvantaged. To be counted towards meeting the goals of the SB Program, a Disadvantaged Business Enterprise must be certified by the California Unified Certification Program.

Early Operating Segment (EOS): The fully electrified, dedicated section of the System upon which the Authority will conduct initial passenger revenue operations. It is approximately 171 miles in length beginning on the north side of Merced Station at R street in Merced and extending to the south side of the Bakersfield Station at Chester Avenue in Bakersfield.

Equity Member: any Person having an ownership interest in the entity that is Contractor, including any joint venture member, general partner, or member thereof, if Contractor is a joint venture, partnership, or limited liability company.

Financial Information: The financial information provided in Volume 1B of the Proposal in accordance with Section 6.5 of this ITP.

Financial Statements: Reports compiled by businesses that detail the company's financial activities and health. Generally, consist of balance sheet, income statement, and of changes in cash flow and footnotes.

First Construction Section (FCS): A component of the EOS over which the Authority will complete testing and commissioning activities necessary to certify the System. It is approximately 119 miles in length beginning at Avenue 19 in the County of Madera and extending to Poplar Avenue in the County of Kern.

Governance Framework: The governance and collaboration requirements, structures, and procedures for the Early Operating Segment, that are specified in the draft governance framework document provided by Authority, which will be finalized following development by and input from Interfacing Contractors and updated from time to time.



Grant/Cooperative Agreements: Any federal agreements between the Authority, the Federal Railroad Administration (FRA), the United States Department of Transportation (U.S. DOT), and/or any other federal agency providing terms for expenditure of federal funds, including but not necessarily limited to, FRA Grant Cooperative Agreement numbers FR-HSR-0118-12, as amended (FY 10 Grant), FR-HSR-0009-10-01-07, as amended (ARRA Grant), and Federal Railroad Administration Grant Cooperative Agreement No. 69A36524521070FSPCA (FSP Grant).

Guaranteed Maximum Price: The maximum sum that the Contractor guarantees to the Authority that the Contract Sum for a Work Package will not exceed and represents the maximum sum for which the Authority may be required to pay the Contractor for its performance of all Work necessary to achieve Final Acceptance of a Work Package, which may be adjusted only by duly executed Change Order.

Guarantor: Any Person who is the obligor under any guaranty in favor of the Authority required under the Contract, if applicable.

Guaranty: Each executed guaranty in favor of Authority related to Contractor's performance of the Work.

Interfacing Contractor: A Person engaged or to be engaged by the Authority to design, deliver, manufacturer, construct, and/or maintain or conduct other activities related or adjacent to any portion of the System that interfaces or could interface with the Work.

Key Personnel: Those individuals identified in the Proposer's Proposal to fill the roles specified in the Technical Proposal (Section 6.6.2(e)).

Long-Lead Items: Materials or equipment necessary to complete the Construction Work that are anticipated to take many months to procure and if not procured timely will affect the orderly and timely completion of the Construction Work.

Merced Extension: The northern extension of the Project included in the approved 2020 Central Valley Wye Environmental Documents spanning 33.9 miles, beginning at the northern limit of high-speed rail Construction Package 1 at Avenue 19 in Madera and ending in downtown Merced to the north and at Carlucci Road to the northeast.

Microbusiness: A for-profit small business concern that meets the certification requirements set forth in California Government Code section 14837(d) and California Code of Regulations, title 2 sections 1896.4 (Definitions) and 1896.12



(Eligibility), including but not limited to, its principal office is located in California, its owners reside in California, it is not dominant in its field, and it has an average gross revenue of \$6 million or less over the previous three tax years. To be counted towards meeting the goals of the SB Program, a Microbusiness must be certified by DGS.

Notice to Proceed: A written authorization notice from Authority to Contractor specifying the date on which the Preconstruction Services is to commence.

Open Government Laws: Collectively, the California Public Records Act (Government Code sections 7920.000, et seq.), the Bagley-Keene Open Meeting Act (Gov. Code section 11120 et seq.), and the Freedom of Information Act (FOIA) (5 U.S.C. section 552, as amended by Public Law No. 104-231, 110 Stat. 3048), and other applicable State and federal open records laws.

Party or Parties: Individually referring to the Authority or the Contractor or collectively referring to the Authority and the Contractor, as the context permits.

Person: Any individual or entity, including corporation, limited liability company, sole proprietorship, joint venture, partnership, trust, voluntary association, unincorporated organization, or governmental agency including the Authority.

Proposer: A person or entity that submits a Proposal in response to this Request for Proposals.

Proposer Team: Collectively, the Proposer and its members and Subcontractors.

Project: The 171-mile Early Operating Segment of the System between the cities of Merced and Bakersfield.

Public Records Act: The California Public Records Act, Government Code sections 7920.000, et seq.

Safety Case: The structured argument, supported by evidence, intended to justify that a system is acceptably safe for a specific application in a specific operating environment. Specifically in this case the operation of the railroad at 220mph using Tier III trainsets.

SB Program: The Authority's High-Speed Rail Business Program Plan ([Revised November 2023](#)). A program that sets forth the Authority's requirements for Small Business Participation, Disabled Veteran Business Enterprises, and Disadvantaged Business Entities. See [Policy & Program Plan - California High Speed Rail](#).



Small Business: A for-profit business concern that meets the certification requirements set forth in the California Small Business Procurement and Contract Act in California Government Code section 14837(d) and Title 2 California Code of Regulations sections 1896.4 (Definitions) and 1896.12 (Eligibility), including, but not limited to, that its principal office is located in California, its owners reside in California, it is not dominant in its field, and it has average gross annual revenue of \$18 million or less over the previous three tax years. To be counted towards meeting the goals of the SB Program, a SB must be certified by DGS.

Small Business for the Purpose of Public Works (SB-PW): A for-profit small business that is independently owned and operated, with its principal office located in California, and with owners, officers, members/managers, partners living in California, has an average of \$43 million or less in gross annual receipts over the previous three (3) tax years, is not dominant in its field of operations and has 200 or fewer employees. This certification is issued by the California Department of General Services.

Subcontractor: Any Person with whom Contractor has entered into any Subcontract and any other Person with whom any Subcontractor has further subcontracted any part of the Work, at any tier.

System: The entire high-speed rail system as described in California Proposition 1A (2008), including Phase 1, which shall run from the San Francisco Bay Area to the Los Angeles basin, and Phase 2, which shall run from Sacramento to San Diego.

Third Party Intellectual Property (IP): Intellectual Property owned by any Person unrelated to Contractor.

Track/OCS Design Services Consultant: A person or entity that is engaged by the Authority to perform design services under agreement HSR23-32 which includes the preparation of the design and design support during construction of the Authority's track system, sub-ballast layer, OCS, along-track cable containment, across track ducts, access walkways, fencing, and drainage for the 171-mile Early Operating Segment from Merced to Bakersfield.

Work: All tasks required under the Contract resulting from this RFP.

2.7 Acronyms

ABVP	Apparent Best Value Proposer
ACA	Affordable Care Act
ADA	Americans with Disabilities Act
ARRA	American Recovery and Reinvestment Act of 2009



BIM	Building Information Modeling
CalSTA	California State Transportation Agency
Caltrans	California Department of Transportation
CCR	California Code of Regulations
CEO	Chief Executive Officer or Executive Director
CEQA	California Environmental Quality Act of 1970
CP 1	Construction Package 1
CP 2-3	Construction Package 2-3
CP 4	Construction Package 4
CUF	Commercially Useful Function
DB	Design-Build
DBE	Disadvantaged Business Enterprise
DGS	California Department of General Services
DVBE	Disabled Veteran Business Enterprise
EAM	Enterprise Asset Management System
ECI	Employment Cost Index
EIR	Environmental Impact Report
EIS	Environmental Impact Statement
EOS	Early Operating Segment
ESG	Environmental, Social, and Governance
FCS	First Construction Section
FOIA	Freedom of Information Act
FRA	Federal Railroad Administration
GARs	Gross Annual Receipts
GenAI	Generative Artificial Intelligence
ICCTA	Interstate Commerce Commission Termination Act of 1995
ISO	International Organization for Standardization
ITP	Instructions to Proposers
LMF	Light Maintenance Facility
MB	Microbusiness
M-M	Merced to Madera
MOWF	Maintenance of Way Facility
MVC	Military and Veterans Code
NEPA	National Environmental Policy Act of 1969
NTP	Notice to Proceed
OCS	Overhead Contact System
ODC	Other Direct Cost
OMB	United States Office of Management and Budget
OSDS	Office of Small Business and DVBE Services
PACIS	Public Address and Customer Information System
PCC	Public Contract Code
PG&E	Pacific Gas & Electric
PMP	Project Management Plan



RAMS	Reliability, Availability, Maintainability, Safety
RFP	Request for Proposals
SB	Small Business
SB-PW	Small Business for the Purpose of Public Works
SCADA	Supervisory Control and Data Acquisition
SOP	Statement of Proposal (Proposal)
TM	Traffic Management
TMS	Traffic Management Systems
TO	Task Order
U.S. DOT	United States Department of Transportation

RFP No.: HSR25-89 TSCC ADDENDUM 8 04/01/2026



INSTRUCTIONS TO PROPOSERS

3 Procurement Schedule and Process

This schedule is subject to modification at the sole discretion of the Authority. Proposers will be notified of any change in the RFP Schedule by an addendum to this RFP. Dates subsequent to the Proposal Deadline may be modified at the discretion of the Authority without issuing an addendum to this RFP.

Unless otherwise indicated, all Proposer deadlines are **12:00 p.m. Pacific Time**.

Table 1: RFP Schedule

Key Dates	Activity Description
Wednesday, November 26, 2025	RFP advertised
Tuesday, December 16, 2025	Addendum 1 Issued
Friday, December 19, 2025	Pre-Bid conference location: May Lee Complex 651 Bannon St., Sacramento, CA 95811 (The pre-bid conference is not mandatory)
Monday, December 29, 2025	Site Visit Requests Due (Proposer led and limited to 6 total attendees)
Monday, January 5, 2026, through Friday January 9, 2026	Site Visit; Limited to 1 Proposal Team per day. Area of Focus; CP4 and Southern Railhead, NTP1 & NTP2
Tuesday, January 20, 2026	One-on-One Meetings
Tuesday, January 27, 2026	Addendum 2 Issued
Friday, January 30, 2026	Addendum 3 Issued
Monday, February 9, 2026	Proposer Questions Due by 5:00 p.m. Pacific Time
Wednesday, February 11, 2026	One-on-One Meetings
Tuesday, February 17, 2026	Technical One-on-One Meetings
Friday, February 27, 2026	Addendum 4 Issued

RFP No.: HSR25-89 TSCC ADDENDUM 8 04/01/2026



Wednesday, March 4, 2026	Proposer Questions Addendum 4 Due by 5:00 p.m. Pacific Time
Tuesday, March 10, 2026	Addendum 5 Issued
Thursday, March 12, 2026	Proposer Questions Addendum 5 Due by 5:00 p.m. Pacific Time
Friday, March 20, 2026	Addendum 6 Issued
Monday, March 23, 2026	Proposer Questions Addendum 6 Due by 5:00 p.m. Pacific Time
Monday, March 23, 2026	One-on-One Meetings
Thursday, March 26, 2026	Addendum 7 Issued
Friday, March 27, 2026	Proposer Questions Addendum 7 Due by 5:00 p.m. Pacific Time
Wednesday, April 1, 2026	Addendum 8 Issued
Thursday, April 2, 2026	Proposer Questions Addendum 8 Due by 5:00 p.m. Pacific Time
Friday, April 3, 2026	Authority to Post Responses to All Proposer Questions
Thursday, April 9, 2026	Proposal Due Stipend Agreement Due
Thursday, April 16, 2026	Escrowed Proposal Documents Due by 4:00 p.m. Pacific Time

*All dates subsequent to the Proposal deadline may be modified at the discretion of the Authority without issuing a formal addendum to this RFP.



3.1 Authority's Designated Point of Contact

The Authority's Designated Point of Contact for communications concerning this RFP shall be as follows:

Emily Morrison
California High-Speed Rail Authority
770 L Street, Suite 620
Sacramento, CA 95814
Phone: (916) 324-1541
Email: tscc@hsr.ca.gov

Persons intending to submit Proposals in response to this RFP shall not contact or discuss any items related to this process with any Authority Board member or Authority staff other than the Point of Contact listed above either directly or through intermediaries. Failure to comply with this communication prohibition may result in disqualification. See Section 3.6, Improper Communications and Contacts, for more information.

3.2 Addenda to RFP

The Authority reserves the right to amend the RFP by addendum or as otherwise permitted in this ITP before the final date of Proposal submission. It is the responsibility of the Proposer to check the California State Contract Register for all addenda.

3.3 Non-Commitment of Authority

This RFP does not commit the Authority to award a contract, to pay any costs incurred in the preparation of a Proposal beyond limits and conditions defined in Section 6.9 (Stipend Payment). In connection with this procurement, the Authority reserves to itself all rights, which may be exercised by the Authority in its sole discretion, available to it under applicable law, including without limitation, with or without cause and with or without notice, the right to the following:

1. Cancel this RFP in whole or in part at any time prior to the execution of a contract without incurring any cost obligations or liabilities.
2. Accept or reject any or all Proposals and all required submittals received as a result of this RFP.
3. Negotiate with any qualified Proposer selected for award.
4. Modify the RFP, in whole or in part.



5. Waive informalities, immaterialities, irregularities, mistakes, and deficiencies in a Proposal; and/or permit clarifications related to such.
6. Issue a new RFP after cancellation of this RFP.

3.4 Property Rights

Proposals received within the prescribed deadline become the property of the Authority and all rights to the contents therein become those of the Authority, with the exception of any Contractor IP and/or Third-Party IP as defined in the Contract. All material developed and produced for the Authority under any Contract resulting from this RFP shall belong exclusively to the Authority and the State of California. All products used or developed in the execution of any Contract resulting from this RFP will be governed by and construed in all respects according to the laws of the State of California, the TSCC Agreement, and the certifications of this RFP.

3.5 Non-Exclusiveness of Subcontractors

Subcontractors are not precluded from being on more than one Proposer Team, subject to the provisions of Section 3.6, Improper Communications and Contacts. There is no prohibition against Subcontractors being exclusive to one Proposer, however, exclusivity is strongly discouraged for SB/DBE/DVBE Subcontractors.

3.6 Improper Communications and Contacts

For purposes of this section, the definitions of Proposer and Proposer Team shall include potential Proposers and potential Proposer Teams as this section specifically applies to all interested parties from the date of issuance of the RFP. The following rules of contact shall apply during this procurement that began upon the date of issuance of this RFP and will be completed with either the execution of the Contract resulting from this procurement, or the cancellation of the procurement. These rules are designed to promote a fair and unbiased procurement process. Contact includes, but is not limited to, face-to-face, telephone, web-based meeting platforms (including viewing/sharing information on screen), text message/SMS, facsimile, email, electronic messaging of any kind or formal written communication. Contact and communications include direct contact or direct communication and those made through an intermediary.

The specific rules of contact are as follows:

1. After submittal of Proposals, no Proposer, or any of its team members, may communicate with another Proposer or its team members with regard to the RFP or any other team's Proposal with the exception of Subcontractors that are shared between two or more Proposer Teams. In such cases, those



Subcontractors may communicate with their respective team members so long as those Proposers establish a protocol to ensure that the Subcontractor will not act as a conduit of information between the teams. Contact among Proposer organizations is allowed during Authority sponsored informational meetings. Protocols established to ensure that Subcontractors do not act as conduits of information between teams are subject to Authority review and approval, at the Authority's discretion.

2. Proposers shall correspond with the Authority regarding the RFP only through the Authority's Designated Point of Contact.
3. Except for communications expressly permitted by the RFP or approved in advance by the Authority's Chief Counsel in their sole discretion, no Proposer or representative thereof shall have any ex parte communications regarding the RFP or the procurement described herein with any member of the Authority Board or with any Authority staff. This includes any of the Authority's advisors, contractors, or consultants (and their respective affiliates) that are involved with the procurement.
4. Proposers shall not contact the entities listed below, including any employees, representatives, and members regarding this RFP:
 - a) Federal Railroad Administration (FRA);
 - b) California State Transportation Agency (CalSTA);
 - c) California Department of Transportation (Caltrans);
 - d) California Department of General Services (DGS);
 - e) California High-Speed Rail Authority, including the Authority Board, except as provided in this RFP; and,
 - f) Firms subject to Proposer Ex Parte Communications prohibitions during this procurement (Table 2).
5. The foregoing restrictions shall not, however, preclude or restrict communications with regard to matters unrelated to the RFP, or the procurement, or from participating in public meetings with the Authority or any Authority workshop related to this RFP.
6. Any communication determined to be improper, at the sole discretion of the Authority, may result in disqualification.
7. The Authority will not be responsible for any oral exchange or any other information or exchange that occurs outside the official RFP process.



Table 2: Firms Subject to Proposer Ex Parte Communications Prohibitions During this Procurement

Firms	
2MS Corporation	Abadjis Systems LTD dba, ASLPM
AECOM	Atlas Technical Consultants, LLC
AZTEC Engineering Group	Bluebird Advisors
Cordoba Corporation	D'Leon Consulting Engineers
Egis Rail Inc. USA	Fluor
Grit Force Inc.	Intueor Consulting Inc
Jaquith Consulting	Keish Environmental
KPMG, LLP	Lesura Strategies, LLC
Mott MacDonald, Group Inc.	MPF Inc.
Network Rail Consulting	Nossaman, LLP
Prisk 12	Psomas, Inc
Structural Integrity Associates, Inc.	SYSTRA USA
Turner & Townsend	TYPSA US
VST Engineering, Inc.	Wescom Solutions
Zoon Engineering, Inc.	

3.7 Organizational Conflicts of Interest

The use of the term “Proposer” in this section specifically applies to all interested parties from the date of issuance of the RFP including but not limited to Proposers, potential Proposers, and subcontractors. The Authority has adopted an Organizational Conflicts of Interest Policy (Policy) that will apply to this procurement and the resulting Contract, in addition to the Authority’s Conflict of Interest Code and other applicable requirements. The [Policy](#) can be found on the Authority’s website.

Proposers are advised to carefully review the Policy, and to have their team members review the Policy, since it includes provisions that may:

1. Preclude certain firms from participation in this procurement; and,
2. Affect the ability of a Proposer, its subcontractors, and their Affiliates (as defined in the Policy) to contract with the Authority.

Failure to comply with the Policy in any respect, including the failure to disclose any actual, perceived, or potential organizational conflict of interest, may result in serious consequences as described in section V(2) of the Policy.

An organizational conflict of interest is a circumstance arising out of a Proposer or Contractor’s existing or past activities (including projects outside of the Authority’s program), business or financial interest, familial relationships, contractual



relationships, and/or organizational structure (i.e., parent entities, subsidiaries, Affiliates, etc.) that results in or would result in the following:

- i. Impairment or potential impairments of a Proposer or Contractor's ability to render impartial assistance or advice to the Authority or of its objectivity in performing work for the Authority;
- ii. An unfair competitive advantage for any Proposer submitting a Proposal on an Authority procurement; or
- iii. A perception or appearance of impropriety with respect to any of the Authority's procurements or contracts, or a perception or appearance of unfair competitive advantage with respect to a procurement by the Authority (regardless of whether any such perception is accurate).

If an organizational conflict of interest is found to exist, the Authority may:

- A. Disqualify the Proposer; or
- B. Determine that the Authority may contract with such Proposer if it is appropriate and possible to mitigate, neutralize, or avoid such conflict, which may include the addition of mitigation provisions to in the Contract awarded.

Each Proposer shall fully disclose any actual, perceived, or potential organizational conflicts of interest in its Proposal using Form H, Organizational Conflicts of Interest Disclosure Statement. Form H shall be filled out and signed, under penalty of perjury, by the Proposer, including a separate Form H for all members if proposing as a joint venture. A separate Form H shall also be filled out and signed, under penalty of perjury, by each Proposer Team member, including all subcontractors. Form H requires a statement, signed under penalty of perjury by the company's executive that the company considered the Policy and performed conflicts checks prior to submitting its Proposal. The refusal to provide the required disclosure, or any additional information required, may result in disqualification of the Proposer. If nondisclosure or misrepresentation is discovered after award of the Contract resulting from this procurement process, the Contract may be terminated.

Note that business relationships on projects other than the California High-Speed Rail project may require disclosure if they involve consultants or contractors working on the California High-Speed Rail project.

By submitting its Proposal, each Proposer agrees that, if an organizational conflict of interest is discovered following submittal of the Proposer, including after any contract award arising out of this RFP process, the Proposer will make an immediate and full written disclosure to the Authority that includes a description of the action taken, or proposed to be taken, to avoid or mitigate such conflicts. To the extent applicable, the Contractor is required to self-certify annually that all



required organizational conflict mitigations are in place, and Authority Contract Managers will enforce and provide oversight for required conflict mitigations.

If a Proposer requires an organizational conflict of interest determination related to this procurement, please immediately consult the Policy and provide the required information to the Chief Counsel at Legal@hsr.ca.gov with a copy to the following attorney for this procurement, Elena M. Pacheco, Elena.Pacheco@hsr.ca.gov. The determination may take between two to four weeks from receipt of all required information and/or documents in the checklist below. To expedite the determination process, the requestor is asked to provide the following information with the request:

Organizational Conflict of Interest Checklist:

- (1) A summary of each of your company's current and former contracts with the Authority, either as a contractor or subcontractor (include project section(s), if applicable, and the current status).
- (2) A brief description of the scopes of work for the above-identified contracts, including tasks, deliverables, and key roles of personnel, if applicable.
- (3) A brief description of the work, tasks, deliverables, and any key roles that your company expects to perform relative to the contract resulting from this procurement. (If not yet final, please be as detailed as possible.)
- (4) A statement about whether your company or principals/employees of your company had any role in the development of this procurement or scope of work.
- (5) A statement about whether your company or principals/employees of your company have learned, received, or were privy to any non-public information regarding the scope of work, content, or development of this procurement.
- (6) Information regarding the type of entity and/or corporate make-up of your company (for example, an LLC, sole proprietorship, corporation, etc.). If applicable, include whether it is a subsidiary of another company and/or if it is owned, in whole or in part, by another contractor working on the project.
- (7) If your company is planning to seek work related to other Authority procurements, provide information regarding the procurement and the scope of work your company would likely perform.
- (8) Any other information and/or documents that you believe are relevant to this analysis, including information regarding other public projects your company is a part of that may impact the Authority.

Please note that the Policy does not address all applicable requirements that may affect persons and entities wishing to enter into contracts with the Authority. Examples of such requirements include but are not limited to: (a) the California Political Reform Act and regulations promulgated by the California Fair Political Practices Commission; (b) restrictions in Public Contract Code section 10365.5 with respect to certain contractors engaged to perform consulting services; and



(c) applicable rules of conduct established by the California Board for Professional Engineers, Land Surveyors, and Geologists.

3.7.1 Organizational Conflicts of Interest for Future Contracts

Pursuant to the Authority's Organizational Conflict of Interest Policy, the successful Proposer may be precluded from participating on future contracts. A contractor may also request an organizational conflict of interest determination utilizing the same contact information as above for any questions that arise.

3.8 Confidentiality and Proposer Work Product

All written correspondence, exhibits, photographs, reports, printed material, tapes, electronic disks, and other graphic and visual aids submitted to the Authority during this procurement process, including as part of a response to this RFP are, upon receipt by the Authority, the property of the Authority and are subject to the Open Government Laws. None of the materials will be returned to the submitting parties. Any materials that are delivered to FRA are subject to the Freedom of Information Act (FOIA) or other federal open records laws. Proposers should familiarize themselves with the Open Government Laws, including the Public Records Act and FOIA. In no event shall the State, the Authority, FRA, or any of their agents, representatives, contractors, directors, officers, or employees be liable to a Proposer or Proposer Team member for the disclosure of all or a portion of a Proposal submitted in response to this RFP, or other information provided in connection with this procurement.

If a Proposer has special concerns about information that it desires to make available to the Authority, but which it believes constitutes a trade secret, proprietary information, or other information exempt from disclosure, such Proposer should specifically and conspicuously designate that information as "TRADE SECRET" or "CONFIDENTIAL" in its Proposal. Blanket, all-inclusive identifications by designation of whole pages or sections as containing proprietary information, trade secrets, or confidential commercial or financial information shall not be permitted and shall be deemed invalid. The specific proprietary information, trade secrets, or confidential commercial and financial information must be clearly identified as such. Under no circumstances, however, will the Authority be responsible or liable to the Proposer or any other party for the disclosure of any such labeled materials, whether the disclosure is deemed required by law, by an order of court, or occurs through inadvertence, mistake, or negligence on the part of the Authority or its officers, employees, contractors, or contractors.



The Authority will not advise a submitting party as to the nature or content of documents entitled to protection from disclosure under the Public Records Act, FOIA, United States Department of Transportation (U.S. DOT) FOIA regulations (49 C.F.R. section 7.17) or other applicable laws and implementing regulations, as to the interpretation of the Public Records Act or FOIA, or as to the definition of trade secret. The submitting party shall be solely responsible for all determinations made by it under applicable laws and for clearly and prominently marking each and every page or sheet of materials with “TRADE SECRET” or “CONFIDENTIAL” as it determines to be appropriate. Each submitting party is advised to contact its own legal counsel concerning the Public Records Act, FOIA, and other applicable laws and their application to the submitting party’s own circumstances. In the event of litigation concerning the disclosure of any material submitted by the submitting party, the Authority’s sole involvement will be as a stakeholder retaining the material until otherwise ordered by a court, and the submitting party shall be responsible for otherwise prosecuting or defending any action concerning the materials at its sole expense and risk. The submitting party shall reimburse the Authority for any expenses it incurs in connection with any such litigation.

3.9 Executive Order N-6-22 – Russia Sanctions

On March 4, 2022, Governor Gavin Newsom issued Executive Order N-6-22 regarding Economic Sanctions against Russia and Russian entities and individuals. “Economic Sanctions” refers to sanctions imposed by the U.S. government in response to Russia’s actions in Ukraine, as well as any sanctions imposed under State law. By submitting a Proposal, Proposer represents that it is not a target of Economic Sanctions. Should the Authority determine Proposer is a target of Economic Sanctions or is conducting prohibited transactions with sanctioned individuals or entities, that shall be grounds for rejection of the Proposal any time prior to contract execution, or, if determined after contract execution, shall be grounds for termination by the Authority.

3.10 Equal Employment Opportunity and Nondiscrimination

The Contractor will be required to follow State and federal Equal Employment Opportunity and Nondiscrimination laws and regulations.

Proposers are advised that the Contractor shall not discriminate against any employee or applicant for employment or harass or allow harassment of any employee because of race, religious creed, color, national origin, ancestry, physical disability, mental disability, medical condition, genetic information, marital status, sex, gender, gender identity, gender expression, age, sexual orientation, or



military and veteran status. The Contractor shall ensure that the evaluation and treatment of their employees and applicants for employment are free of such discrimination. Actions covered by these laws and regulations shall include, but are not limited to employment, upgrading, demotion or transfer, recruitment or recruitment advertising, layoff or termination, rates of pay or other forms of compensation, and selection for training, including apprenticeship.

The Proposer is also advised that the Contractor must comply with section 1735 of the California Labor Code, which reads as follows: A contractor shall not discriminate in the employment of persons upon public works on any basis listed in subdivision (a) of section 12940 of the Government Code, as those bases are defined in sections 12926 and 12926.1 of the Government Code, except as otherwise provided in section 12940 of the Government Code. Every contractor for public works who violates this section is subject to all the penalties imposed for a violation of this chapter.

3.11 Labor Compliance

The Proposers are advised that the Contractor must comply with all applicable federal and state labor laws and regulations, the applicable Department of Fair Employment and Housing regulations, and applicable Nondiscrimination and Compliance regulations. Proposers are advised of the [Memorandum of Understanding \(MOU\) dated November 16, 2023](#) between the Authority and Signatory Labor Organizations which addresses employees doing traditional rail work to support the Authority's revenue operations and the applicability of the Railway Labor Act.

3.12 The California Environmental Quality Act

By issuing this RFP, and by entering into any resulting Contract that mentions or refers to the California Environmental Quality Act (CEQA), Environmental Impact Report (EIR), and State environmental permitting laws/agencies and initially authorizes related work, the Authority does not: (a) waive the Authority's rights regarding the application of the Interstate Commerce Commission Termination Act of 1995 (ICCTA), including the defense that ICCTA preempts CEQA's application to the System; or (b) create an implied agreement that CEQA and/or such environmental permitting requirements apply to the System.

3.13 Liability, Insurance, and Performance Security

The Contract will require the Contractor to assume liabilities, to provide performance and payment bonds and insurance coverage, and to indemnify and defend the Authority against third-party claims as specified in the Contract. The



Authority will have the benefit of tort liability limitations to the extent provided by State law. Neither the State nor the Authority intends to waive their respective sovereign immunity protections under State law. Specific provisions concerning performance and payment bonds, guarantees, insurance, and indemnity can be found in the TSCC Agreement in sections 7, 25, and 26 and Schedule 25 to the TSCC Agreement.

3.14 Generative Artificial Intelligence Disclosure Notification Requirements

The State of California seeks to realize the potential benefits of Generative Artificial Intelligence (GenAI), through the development and deployment of GenAI tools, while balancing the risks of these new technologies.

Each Proposer must notify the State in writing if it: (1) intends to provide GenAI as a deliverable to the Authority; or (2), intends to utilize GenAI, including GenAI from third parties, to complete all or a portion of any deliverable that materially impacts: (i) functionality of an Authority system, (ii) risk to the Authority, or (iii) Contract performance.

For avoidance of doubt, the term “materially impacts” shall have the meaning set forth in State Administrative Manual (SAM) § 4986.2 Definitions for GenAI.

Failure to report GenAI to the Authority may result in disqualification of the Proposer. The Authority reserves the right to seek any and all relief to which it may be entitled to as a result of such non-disclosure.

Upon notification by a Proposer of GenAI as required, the Authority reserves the right to incorporate GenAI Special Provisions into the final contract or reject bids/offers that present an unacceptable level of risk to the Authority.

3.15 Small Business Program and Small Business Performance Plan

The Authority's [HSR Small Business Program Plan, November 2, 2023](#) (HSR SB Program Plan) is in compliance with the Best Practices of 49 C.F.R. Part 26, Government Code §§ 4532-4535, 11148.5, 12098.4, and 14835-14846, California Executive Orders S-02-06 and D-43-01, Military and Veterans Code 999, Title VI of the Civil Rights Act of 1964, and related statutes. This Contract is anticipated to be funded with blended state and federal funds. For contracts with blended funds, the HSR SB Program Plan establishes a 25 percent Small Business (SB) goal on the state portion of the contract, which includes a 3 percent Microbusiness (MB) goal; a separate 10 percent Disadvantaged Business Enterprise (DBE) goal, which will be applied across the total contract value; and a separate 3 percent Disabled Veteran Business Enterprise (DVBE) goal, which will be applied across the total contract value.



On October 3, 2025, the U.S. Department of Transportation (USDOT) issued an Interim Final Rule (IFR) making changes to its DBE program (49 CFR Part 26), effective immediately. Pursuant to 49 CFR 26.55(i) and 49 CFR 26.52(h), the Authority will not count DBE participation towards the above-referenced 10 percent DBE goal and will not apply the 10 percent DBE goal *until* the applicable Uniform Certification Program(s) have completed the 49 CFR 26.111 reevaluation process for a business. During the pendency of the 49 CFR 26.111 reevaluation period, the Authority will not enforce contractual DBE goals. Remaining portions of the USDOT DBE program and the HSR SB Program Plan remain in effect, including but not limited to the 25 percent SB goal, inclusive of the 3 percent MB goal, and the 3 percent DVBE goal. Once the 23 CFR 26.111 reevaluation process for a business is completed by an applicable UCP, the Authority will resume counting DBE participation towards the 10 percent DBE goal in this Agreement. The Authority and its consultants will comply with all applicable USDOT and appropriate USDOT modal agency modifications to the federal DBE program. Accordingly, to the extent necessary for compliance purposes, the DBE contract requirements in this Agreement are subject to revision.

For this Contract, the anticipated total funds are not-to-exceed \$3.5 billion. For the purpose of Proposals, Proposers can assume NTP 1 and NTP 2 will each contain anticipated proportions of 20 percent federal to 80 percent State funding, subject to State Small Business requirements.

The Authority is not a certifying agency for Small and Disadvantaged Businesses. The qualifying certifications can be obtained through DGS (SB, MB, Small Business for the Purpose of Public Works (SB-PW), DVBE) and California Unified Certification Program (DBE).

The Proposal shall include the Proposer's Overall Project Small Business Goal Commitment Affidavit (Cert. 12), confirming the Proposer's commitment to meet or exceed the HSR SB Program Plan goals. The Proposer is advised to review the Authority's HSR Small Business Program Plan for further guidance.

The Contractor shall establish and implement an SB/DVBE/DBE Performance Plan (SB Performance Plan) to address how the Contractor will meet the goals throughout the duration of the Contract. Contractor's SB Performance Plan shall be subject to concurrence by the Authority. Commitments in the Proposal related to the proposed SB Performance Plan will become part of Contractor's SB Performance Plan. The SB Performance Plan will include a detailed Communication Plan, describing the approach and frequency with which the Contractor will use to communicate with SB/MB/SB-PW/DBE/DVBE



Subcontractors. The SB Performance Plan shall be part of the Proposer's submission in Volume 2 (Technical Proposal) of its Proposal. Please see Section 6.6.2(k) for further information.

3.16 Small Business Communication Plan

To the extent applicable, as determined in the sole discretion of the Authority's Small Business team, the Contractor shall establish and implement a Communication Plan that defines the approach and frequency that Contractor shall use to communicate with SB/DBE/DVBE Subcontractors. The Communication Plan will assist in systematic information sharing and two-way communication. The Communication Plan shall encompass the following:

- A. Project plan, status, budget, change requests and risk management;
- B. Assignments, status, work in progress, issues and risk tracking, and lessons learned;
- C. Schedule and deadlines, status, and any delays; and
- D. List of contact people and information with whom the SB/DBE/DVBE Subcontractors will be interacting.

The Contractor shall submit monthly reports that detail the information communicated to SB/DBE/DVBE Subcontractors regarding schedule, deadlines, status, and delays.

Please see Section 6.6.2(l) for further information.

4 Submittal of the Proposal

4.1 Proposal Submittal Information

Proposals submitted in response to this RFP shall be provided in electronic and hard copy formats as required by Section 6 of this RFP. Hard copies shall be mailed or hand delivered to:

California High-Speed Rail Authority
Attention: Emily Morrison
770 L Street, Suite 620 MS 2
Sacramento, CA 95814



The following information must be placed on the lower left corner of the submittal shipping packages:

RFP No.: HSR25-89

California High-Speed Rail Authority
Track and Systems Construction Contract Proposal

Proposer: _____

**ONLY TO BE OPENED BY AUTHORITY'S DESIGNATED
POINT OF CONTACT**

Due to building access restrictions, Proposers that will hand deliver their Proposals are requested to notify the Authority's Designated Point of Contact identified in Section 3.1 at least 24 hours before their anticipated arrival time. Proposers that will deliver their Proposals by mail are requested to notify the Authority's Designated Point of Contact of the expected delivery date.

4.2 Late Submittals

Proposals received after the specified date and time are considered late and will not be accepted. There are no exceptions. Postmark dates of mailing, email, and facsimile transmissions are not accepted under any circumstances and are not acceptable toward meeting the submission deadline for delivery. A Proposal is late if received any time after the date and time listed in Table 1. Proposals received after the specified time will not be considered and will be returned unopened to the Proposer. Proposers are responsible for requesting a receipt or delivery confirmation for delivery of their Proposal.

4.3 Modification or Withdrawal of Proposals

Any Proposal received may be withdrawn or modified before the Proposal submittal deadline by written request to the Authority that is signed by the Proposer or an authorized agent. A Proposer may thereafter submit a new Proposal prior to the Proposal deadline. The only method for a Proposer to modify its Proposal is by withdrawing its submission in its entirety prior to the Proposal deadline, by written notification to the Authority. A complete, corrected submission package may be resubmitted prior to the Proposal deadline. Modifications offered in any other manner will not be considered.



4.4 Validity of Proposals

All proposals submitted shall be valid for 90 days after the proposal due date.

5 Project Status

The status of significant Project activities is detailed in the following subsections.

5.1 Environmental Analysis

The Work is addressed in the Authority's environmental documents. These include:

- The [Merced to Fresno California High-Speed Train Project Final Environmental Impact Report/Environmental Impact Statement \(EIR/EIS\)](#). The Authority Board certified the Final EIR/EIS on May 3, 2012. FRA issued its Record of Decision (ROD) on September 18, 2012.
- The [Fresno to Bakersfield California High-Speed Train Project Final EIR/EIS](#). The Authority Board certified the Final EIR/EIS on May 7, 2014. FRA issued its ROD on June 27, 2014.
- The [Fresno to Bakersfield Extension Final EIR/EIS](#). The Authority Board certified the Final Supplemental EIR on October 16, 2018. The Authority issued its Final Supplemental EIS and Supplemental ROD on October 31, 2019.
- The [Merced to Fresno Central Valley Wye Final Supplemental EIR/EIS](#). The Authority Board certified the Final Supplemental EIR/EIS on September 10, 2020. The Authority issued its Supplemental ROD on September 16, 2020.

The Contractor's actions under the Contract to deliver the Work must be consistent with the descriptions and assumptions in these environmental documents.

The Contractor's actions under the Contract to deliver the Work must also be consistent with environment justice requirements contained in: Federal Title VI/Limited English Proficiency requirements or any subsequent U.S. Department of Transportation requirements, and all applicable state language access requirements including the Dymally-Alatorre Bilingual Services Act.

The Contractor's actions under the Contract to deliver the Work must also be consistent with the Authority's Sustainability Policy (POLI-1007), which commits the Authority to work toward net-zero water consumption during operations with compliance with the California Green Building Standards Code, net-zero energy



consumption with facilities LEED-certified at the Platinum level and using 100 percent renewable energy for operation.

Technical proposals should, where applicable, demonstrate compliance with these above-referenced requirements.

5.2 Governmental Approvals

The Authority has obtained or will obtain the Authority-Provided Governmental Approvals as identified in section 11 of the TSCC Agreement. The Contractor will be responsible for obtaining all other Governmental Approvals and other Supplemental or Amended Governmental Approvals required.

Additional conditions or mitigation measures may be required by law as a result of the issuance or amendment of Governmental Approvals. It is also possible that Supplemental or Amended Governmental Approvals may be required by law for the Project, which may impose additional conditions or required mitigation, avoidance and minimization measures not previously identified.

5.3 Right-of-Way

The Authority intends to provide the Contractor with sufficient Right-of-Way (ROW) to contain the limits of construction in support of the alignment and scope of work for this solicitation. Unless otherwise stated in the Contract, the Work must be designed and constructed within such limits.

5.4 Railroads

The Authority is coordinating with railroads that may be impacted by the Project. Railroad Agreement Terms are included in Schedule 15 to the TSCC Agreement.

5.5 Reserved

Reserved.

5.6 Federal Requirements

Since this Project will receive federal funding, the RFP and any construction contract awarded by the Authority shall be subject to the requirements of applicable federal law, federal regulations and conditions in the Grant/Cooperative Agreements. The Authority reserves the right to modify the RFP, including the Contract documents, to address any concerns, conditions or requirements of the funding agencies, including FRA. The full Grant/Cooperative Agreements, including additional requirements are available for review on the Authority's website at [Funding Agreements](#).



5.7 Buy America Requirements

The federal Buy America requirements for this contract are as described in this section. The Proposal must comply with these requirements to be considered.

5.7.1 Overview

This Project is subject to FRA's "Buy America" statute at 49 U.S.C. § 22905(a) and applicable FRA guidance (see [FRA Buy America Frequently Asked Questions](#)) and the Build America, Buy America Act (BABA) and 2 C.F.R. 184.6, requiring all construction materials used in an FRA-funded project to be produced in the United States. Collectively, these requirements are referred to as Buy America.

49 U.S.C. § 22905(a) allows the U.S. Secretary of Transportation to obligate funds for "a project only if the steel, iron, and manufactured goods used in the project are produced in the United States." FRA's High Speed Intercity Passenger Rail Project is intended, in part, to bolster American passenger rail expertise and resources, and the Buy America requirements reinforce this goal and aid in encouraging a domestic market in the rail sector.

FRA has issued to the Authority a nonavailability waiver applicable to certain components. Reference Docket No. FRA-2024-0104 at 89 FR 94868.

The Authority is not seeking price submittals on the applicable components with this RFP, but for purposes of Proposals and this RFP, Proposers may assume these waivers will be granted. Instructions below for required Buy America Certification take this into consideration. If the waivers are not granted, appropriate amendments will be made to the RFP and/or the Contract. Proposers shall not assume that any additional waivers will be granted beyond the components listed above.

The Buy America requirements of this RFP comprise two parts:

Part I – Buy America Certification and Waiver Justification: Proposers must submit a completed and signed "Buy America Compliance or Non-Compliance Certificate" (Cert. 8) to indicate that all Work will be Buy America compliant or that a waiver(s) will be required. If the Proposer states that a waiver(s) will be required, the Proposer shall submit sufficient written justification and documentation to support and process, if necessary, the waiver(s) with the Certificate of Non-Compliance (Cert. 8).

Part II – Buy America Audits: The Buy America process for this procurement may include pre-award and post-delivery audits. The Authority and/or its representative will also provide ongoing oversight of the Contractor's Buy America compliance during the Contract term.



5.7.2 Part I: Buy America Certification

Proposers shall complete and submit the following:

1. Completed and signed Buy America Certificate of Compliance or Non-Compliance (Cert. 8); and
2. If applicable: Any Buy America waiver written justification (see Section 5.7.2.2 below for detailed requirements).

Proposer certifications and waiver justifications are subject to FRA/Authority audit, and Proposer and its suppliers agree that, in submitting a proposal, they will provide all required information to support any such audit(s).

5.7.2.1 Buy America Certificate

Each Proposer shall submit the appropriate Buy America Certification (Cert. 8). Proposals not accompanied by properly completed Buy America Certification may be rejected as nonresponsive.

The two signature blocks on Cert. 8 are mutually exclusive. Proposers shall sign ONLY ONE signature block on the certificate. Signing both Cert. 8 signature blocks may render the Proposal nonresponsive. Making a knowing and willful false certification is a criminal act in violation of 18 U.S.C. §1001.

Proposer is bound by the certification(s) submitted with its Proposal and is not permitted to change its certification(s) after submission of the Proposal unless the requirements of 49 U.S.C. § 22905(a)(9) are met.

For a Proposer that certifies it cannot comply with the requirements of 49 U.S.C. § 22905(a)(1) on Cert. 8 but may meet the requirements for a waiver pursuant to 49 U.S.C. 22905(a)(2): the written justification provided to support this selection may include reference to the FRA's Notice of Final Nonavailability Waiver of Buy America Requirements for the Program (available at [Federal Register :: Notice of Final Nonavailability Waiver of Buy America Requirements for Certain High-Speed Rail Products for the California Inaugural High-Speed Rail Service Project](#) where such notice includes



the same components for which the Proposer requires a waiver (see Section 5.7.2.2 for more details).

The Authority reserves the right to require Buy America certification submittals during the term of the Contract at appropriate times (such as with Contractor's submittal of a Work Package Proposal).

5.7.2.2 Written Justification for Waiver

If a Proposer certifies it cannot comply with the requirements of 49 U.S.C. § 22905(a)(1) on Cert. 8, it shall submit a written justification detailing the reasons it believes it meets the particular waiver exception(s). The written justification provided should also include a statement detailing the percentage of U.S. content in each component or end product, as applicable.

At a minimum, the written justification provided per this section should include the following information:

1. Whether a component identified as requiring a waiver is included in the FRA's Notice of Proposed Nonavailability Waiver of Buy America Requirements for the Program referenced above;
2. Description of the component not meeting the FRA Buy America requirement, including the required completed description of the efforts made to secure the component(s).
3. Description of the process used to find U.S. suppliers of component(s) for which a waiver is being requested and such process shows a commitment to finding and/or developing U.S. suppliers in future procurements (Proposers are encouraged to use the services of the [National Institute of Standards and Technology \(NIST\) Manufacturing Extension Partnership \(MEP\)](#) or equivalent supplier scouting service to assist them);
4. Cost differential(s) to secure domestic component(s) as compared with nondomestic component(s);
5. Issues with quality or quantity of compliant component(s) (if applicable);
6. Issues with timely delivery of compliant component(s) (if applicable);



7. Citation to the specific 49 U.S.C. § 22905(a)(2) waiver category(ies) under which the waiver is sought;
8. Justification supporting the application of the waiver category(ies) cited to the extent not already answered by the above;
9. Identification of any risks associated with manufacturing the component in the U.S. (if applicable); and
10. Explain how long it expects to need a waiver and what steps, in detail, Proposer is taking to manufacture this component in the U.S.

5.7.3 Part II – Buy America Audits

Proposer certifications and waiver justifications are subject to FRA/Authority audit, and Proposer and its suppliers agree that, in submitting a proposal, they will provide all required information to support any such audit(s).

The Buy America process for this procurement may include pre-award and post-award audits.

5.8 Pre-Proposal Submittals and Meetings

5.8.1 Notice of Intent to Propose

The Authority intends to conduct one-on-one meetings with interested Proposers that submit a timely Notice of Intent to Propose. Submission of a Notice of Intent to Propose is a prerequisite to participating in meetings with the Authority. The Notice of Intent to propose should be submitted to the Point of Contact listed in Section 3.1 of this ITP, in the form of a letter including:

- Proposer Team and/or Firm Name;
- Proposer Point of Contact and contact information, including phone and email, and
- Statement that the Proposer can meet the minimum requirements of this RFP.

5.8.2 One-on-One Meetings

The Authority shall conduct one-on-one meetings with each Proposer that submits a timely Notice of Intent to Propose on dates designated by the Authority in writing to the Proposers, to discuss issues and clarifications regarding the RFP. The Authority reserves the right to disclose to all Proposers any issues



raised during the one-on-one meetings, except to the extent that the Authority determines, in its sole discretion, such disclosure would reveal a Proposer's confidential business strategies. The meetings are intended to provide Proposers with a better understanding of the RFP.

The one-on-one meetings are subject to the following:

- a. The Authority will not discuss with any Proposer any Proposal other than its own.
- b. Proposers shall not seek to obtain commitments from the Authority in the meetings or otherwise seek to obtain an unfair competitive advantage over any other Proposer.
- c. No aspect of these meetings is intended to provide any Proposer with access to information that is not similarly available to other Proposers, and no part of the evaluation of Proposals will be based on the conduct or discussions that occur during these meetings.
- d. Persons attending the one-on-one meetings will be required to sign an acknowledgment of the foregoing rules and to identify all participants from Proposer Team.

5.8.3 Nondisclosure Agreement for Confidential Reference Materials

Proposers should reference Section 2.5(d) and Form P of this ITP for information regarding the Nondisclosure Agreement required to access Confidential Reference Materials.

5.8.4 ATC Process

Note to Proposers: The Authority has removed the Alternative Technical Concept process as a reflection of the revised pricing approach and level of design provided at this time for the applicable Packages. The Authority has included a process for value-added alternative concepts and TSCC Contractor-initiated optimizations as final Package designs and prices are developed; see section 23.6.3 of the TSCC Agreement. Further discussions on innovation approaches in the forthcoming one-on-one meetings are encouraged.



PROPOSALS

6 Proposal Submittal Requirements

6.1 Compliant Proposal

The Proposal shall document the Proposer's qualifications, technical approach to Project delivery, capability to deliver the Project, and proposed price elements for the Work as requested in this ITP and in consideration of the evaluation criteria.

The Proposal must contain sufficient detailed information to enable the Authority to make an adequate evaluation of the Proposer's understanding of the Project's scope, cost and implementation challenges and the Proposer's technical, organizational, and financial capability to perform in the supply-maintain role for the Project and to complete the Project successfully. The Authority may ask Proposers individually or collectively for additional information or clarification regarding their Proposals.

Proposals that do not demonstrate complete compliance with the requirements of the following sections may be rejected by the Authority and result in disqualification of the Proposer(s).

Proposers are reminded that the Authority intends to administer the Contract focusing on collaboration, trust, transparency, and mutual active involvement between the Contractor and the Authority at all stages of the Work. These qualities should be prominently displayed in the Proposal and will be considered towards its evaluation.

6.2 Format Requirements

To facilitate the evaluation of Proposals and to help protect the confidentiality of proprietary information the volumes of the Proposal submittal described in this ITP shall be submitted in separately sealed packages.

The Proposal shall be submitted on the forms furnished or copies thereof and shall be completed in ink or typewritten. All letters and forms shall be manually or digitally signed. All blank spaces in the Proposal forms must be completed as noted. No substantive change(s) shall be made to the Proposal forms furnished herein. Any failure to provide all information and all completed forms in the format specified by the ITP may result in the Authority's rejection of the Proposal depending on the nature of the omission.



Documents must be prepared on letter sized 8-1/2" x 11" white paper. Ledger sized 11" x 17" pages are allowed for schematics, organizational charts, other drawings and schedules, but not for narrative text. All written submittals, regardless of paper size, must be included in the applicable volume. A single side of an 8-1/2" x 11" or 11" x 17" sheet will be considered one page. Pages shall be numbered at the bottom to show the page numbers and total number of pages in the response (e.g., Page 1 of 10, Page 2 of 10, etc.).

Each section within a volume shall be separated by a divider with a tab and shall be prepared using no smaller than 12-point font size, except for tables and graphics, which may be prepared using 10-point font size. The Authority may disregard documents not complying with these requirements. Proposers shall not include standard corporate brochures, awards, and/or marketing materials; the Authority will not evaluate such materials.

6.3 Contents and Organization

Proposals shall be composed of the Proposer's **Administrative Submittals** (Volume 1A), **Financial Information** (Volume 1B), **Executive Summary** and **Technical Proposal** (Volume 2) and **Price Proposal** (Volume 3). For avoidance of doubt, Volumes 1A and 1B shall be considered separate Volumes. Each Volume shall be provided in a separate three ring binder. 11x17 design drawings may be submitted using binding post screws or similar binding format or larger sized (i.e., 11x17) binders more appropriate for oversized materials. Proposers shall clearly index their Proposals using pages with tabs and organize them in the order set forth in this ITP Section 6.

Each Proposer shall provide a digital copy of its entire Proposal, except for Volume 3. Proposer shall not include Volume 3 with the electronic submittals and shall provide one original of Volume 3 only. The digital copy shall be submitted via cloud storage that the Authority will provide.

6.3.1 Digital Submission Requirements

Each Proposer should email the Authority's Designated Point of Contact listed in Section 3.1 of this RFP at least two Business Days before the anticipated submittal of its Proposal. The email request should include:

- Proposer's team name;
- Proposer's email address; and
- The RFP number



After receipt of the Proposer's email request, the Authority's Designated Point of Contact will provide a link to each Proposer to a unique and secure cloud folder to upload its Proposal. Failure to notify the Authority two Business Days in advance may cause delays in the Proposer's receipt of an upload link and impact its ability to upload its Proposal in a timely manner. Proposals must be received in the specified location no later than the date and time listed in Section 3, Table 1, and addressed in accordance with Section 4.1. The Authority has discretion to work with a Proposer in the case of technical issues for electronic submittals.

Each Volume, except Volume 3, should be provided as a separate PDF file and should be printable, searchable, appropriately bookmarked to reflect the organizational structure set forth in this ITP Section 6, in a read-only format, and should not require a password to open or print. Each file name should include the RFP number, volume number, and Proposer team name as follows: HSR25-89_JohnDoeConsulting_Vol X.pdf.

6.4 Volume 1A – Administrative Submittals

Volume 1A of the Proposal will contain the Administrative Submittals. The required contents and organization of Volume 1A is presented in this Section. Each Proposer shall submit one (1) original and five (5) written hard copies (for a total of 6) of Volume 1A. The original must be clearly marked "Original" on its face and spine. Each copy must be numbered 1 through 5 on its spine.

Volume 1A shall be organized with a tab for each Proposer Team member identified in Form B, and all required administrative submittals for that respective team member shall be included together.

Proposer shall provide the following forms, certifications, and other information in Volume 1A:

Transmittal Letter (Form A) – The Proposer shall complete the Transmittal Letter (Form A) and attach evidence of its authorized representative(s) to execute and deliver the Proposal and the Contract, Letters of Commitment from Subcontractors (including all Key Subcontractors) required by Section 6.6.2(d), signed statements from Key Personnel required by Section 6.6.2(e), and Key Personnel resumes as described in Section 6.6.2(e).

Additionally, all Key Personnel shall submit a signed statement indicating that they understand the project office will be located either at the Authority's Sacramento headquarters located at 770 L Street, Sacramento, CA 95814 or in the Central Valley and are willing to work full time at that location as determined by the work schedule.



Identification of Proposer’s RFP / Proposal Manager (Form B) – The Proposal shall contain a completed Form B, identifying its Proposal Manager.

Information about Proposer, Equity Members, Lead Designer, Lead Contractor, and Guarantors (Form C) - The Proposal shall contain a completed Form C for the Proposer, each Equity Member, Lead Designer, Lead Contractor, and any proposed Guarantor identified on Form D.

Identification of Proposer Team Members (Form D) – The Proposal shall contain a completed Form D identifying each Proposer Team member, its role on the Proposer Team and its Official Representative for the purposes of executing any required forms or certifications included in the Proposal. All Subcontractors identified on Form D shall also be listed on Form F.

Key Personnel Matrix (Form E) – The Proposal shall contain a completed Form E confirming the availability of Key Personnel. This form shall be signed by the Proposer’s Official Representative.

Schedule of Subcontractor(s) (Form F) – The Proposal shall contain a completed Form F with information regarding anticipated Subcontractors and signed by the Proposer’s Official Representative. Subcontractors identified on Form D shall also be listed on Form A. All Subcontractors listed on Form D must be registered with the Department of Industrial Relations (DIR) pursuant to Labor Code section 1725.5 as applicable. Evidence that Subcontractors listed on Form F are registered with DIR shall be provided in Volume 1A of the Proposal.

Past Performance Certification (Form G) – The Proposal shall contain a complete Form G for the Proposer, each Equity Member, the Lead Contractor, and each Guarantor identified in Form D (Identification of Proposer Team Members).

Organizational Conflicts of Interest Disclosure Statement (Form H) – The Proposal shall contain a completed Form H signed by the Proposer’s Official Representative. Additionally, each Proposer Team member identified on Form D shall submit a copy signed by its Official Representative as identified in Form D.

Verification, Validation, and Self-Certification Commitment (Form I) – The Proposal shall contain a statement of Proposer’s unequivocal commitment to comply with the Authority’s Verification, Validation, and Self-



Certification requirements, which are stated in RM.32, signed by Proposer's Official Representative.

Proposed Table of Rates and Prices (Form J1) – Not part of the Administrative Submittals. To be included only in Volume 3 (Price Proposal) pursuant to Section 6.7 of this ITP.

Price Proposal Summary (Form J2) – Not part of the Administrative Submittals. To be included only in Volume 3 (Price Proposal) pursuant to Section 6.7 of this ITP.

Past Projects (Form K) – The Proposal contains a fully completed Form K, "Past Projects" for each project identified in response to Section 6.6.2(b) of the Technical Proposal. Form K shall be submitted for at least three (and no more than five) projects with a Project Construction Value over \$1 billion.

Project Owner References (Form L) – The Proposal contains a fully completed Form L, "Project Owner References" for each project for which the Proposer submitted a Form K.

Key Personnel References (Form M) – The Proposal contains a fully completed Form M, "Key Personnel References" for each reference for each firm identified in a Key Personnel position. Each firm identified in a Key Personnel position shall have two references.

Disabled Veteran Business Enterprise Declaration (Form N) – If Proposer intends to utilize one or more Disabled Veteran Business, the Proposal should contain a DGS PD 843, [Disabled Veteran Business Enterprise Declaration](#).

Past Performance Questionnaire (Form S) – The Proposal shall contain a completed Form S signed by the respective Official Representative for the Proposer, each Equity Member, Lead Contractor, Lead Designer, and any Guarantor.

Debarment, Suspension, Ineligibility, and Voluntary Exclusion Certification (Cert. 1) – The Proposal shall contain a completed Cert. 1 signed by the respective Official Representative for the Proposer and each member of the Proposer Team identified on Form D.

Non-Collusion Affidavit (Cert. 2) – The Proposal shall contain a completed Cert. 2 for the Proposer signed by the Proposer's Official Representative.



Organizational Conflicts of Interest Affidavit (Cert. 3) – The Proposal shall contain a completed Cert. 3 signed by the Official Representative for the Proposer. The Proposal shall also contain a completed Cert. 3 signed by the Official Representative for each member of the Proposer Team identified on Form D.

Equal Employment Opportunity Certification (Cert. 4) – The Proposal shall contain a completed Cert. 4 signed by the Official Representative for the Proposer. The Proposal shall also contain a completed Cert. 4 signed by the Official Representative for each member of the Proposer Team identified on Form D.

Non-Discrimination Certification (Cert. 5) – The Proposal shall contain a completed Cert. 5 signed by the Official Representative for the Proposer. The Proposal shall also contain a completed Cert. 5 signed by the Official Representative for each member of the Proposer Team identified on Form D.

Certification Regarding Lobbying (Cert. 6) – The Proposal shall contain a completed Cert. 6 by the Official Representative for each Equity Member as identified on Form D.

Drug Free Workplace Program Certification (Cert. 7) – The Proposal shall contain a completed Cert. 7 signed by the Official Representative for the Proposer. The Proposal shall also contain a completed Cert. 7 signed by the Official Representative for each member of the Proposer Team identified on Form D.

Buy America Compliance or Non-Compliance Certifications (Cert. 8) – The Proposal shall contain a completed Cert. 8 signed by the Official Representative for the Proposer. The Proposal shall also contain a completed Cert. 8 signed by the Official Representative for each member of the Proposer Team identified on Form D.

Iran Contracting Certification (Cert 9) – The Proposal shall contain a completed Cert. 9 signed by the Official Representative for each Equity Member identified on Form D.

Darfur Contracting Act Certification (Cert. 10) – The Proposal shall contain a completed Cert. 10 signed by the Official Representative for each Equity Member identified on Form D.



Certification Regarding Miscellaneous State Requirements (Cert. 11) –

The Proposal shall contain a completed Cert. 11 signed by the Official Representative for each Equity Member identified on Form D.

Proposer’s Project Small Business Goal Commitment Affidavit (Cert. 12) –

The Proposal shall contain a completed Cert. 12 signed by the Proposer’s Official Representative confirming the Proposer has committed to meet or exceed the overall Project SB goal of 25 percent, inclusive of a 3 percent carveout for Microbusiness, as well as a 10 percent DBE goal and a 3 percent DVBE goal on federally assisted contracts.

California Civil Rights Laws Certification (Cert. 13) –

The Proposal shall contain a completed Cert. 13 signed by the Proposer’s Official Representative.

DGS Forms - CCC 04/2017 and STD 204 (Cert. 14) –

The Proposal shall contain the Contractor Certification Clauses (CCC 04/207) and STD 204 forms. Both forms are available at the hyperlinks provided at Certification 14.

Generative Artificial Intelligence Disclosure (Cert. 15) –

Per Section 3.14, the Proposal must notify the State in writing if it: (1) intends to provide GenAI as a deliverable to the State; or (2), intends to utilize GenAI, including GenAI from third parties, to complete all or a portion of any deliverable that materially impacts: (i) functionality of a State system, (ii) risk to the State, or (iii) Contract performance.

Escrowed Proposal Documentation Certification (Cert. 16) –

– Not part of the Administrative Submittals. To be included with the Escrowed Proposal Documentation pursuant to Section 6.8 of this ITP.

Surety Letter –

Provide a letter from a surety or an insurance company indicating the Proposer’s capacity to obtain bonds consistent with the requirements of section 7 of the TSCC Agreement, subject to reasonable qualifications required by the surety. The surety or insurance company must be registered with the California State Insurance Commissioner, appear on the current Authorized Insurance List in the State of California published by the Office of the Insurance Commissioner and an A.M. Best’s Rating Service classification of A-XIV or better. Letters shall include the Proposer’s bonding capacity, with respect to the specified bonds in section 7 of the TSCC Agreement, for Package 1 and Package 2.



Joint and Several Liability – If the Proposer is a joint venture, the Proposal shall contain a letter signed by each Equity Member indicating that it accepts joint and several liability for the Proposer’s obligations under its Proposal and any resulting contract.

Department of Industrial Relations Registration – The Proposal shall contain proof of DIR registration, for the Proposer and each Equity Member pursuant to Labor Code sections 1725.5 and 1771.1.

Organizational Documents – The Proposal shall contain a copy of the articles of incorporation and bylaws, the joint venture agreement, partnership agreement, limited liability company agreement or equivalent organizational documents for the Proposer, each Equity Member, and Guarantors (if any), such documents shall be consistent with the responsibilities to be undertaken by such parties under the Contract.

Legal Issues, Liabilities or Proceedings – The Proposal shall include a statement explaining what legal issues, liabilities, or proceedings are presently before the Proposer and any Joint Venture Members.

If there are legal issues, liabilities or proceedings at issue, then the Proposal shall include the following information regarding such legal issues, liabilities and proceedings:

- a. **Legal Issues** – Identify and explain any significant anticipated legal issues which the Proposer must resolve in order to carry out the Project and its obligations under the Contract.
- b. **Legal Liabilities** – Provide a list and a brief description of all instances involving similar projects in which the Proposer or Equity Member or its parent company; its subsidiary companies; any company under joint ownership with such firm; any joint ventures or limited liability companies in which such firm is a member; and any partnership in which such firm is a general partner was (i) determined, pursuant to a final determination in a court of law, arbitration proceeding or other dispute resolution proceeding, to be liable for a material breach of contract or (ii) terminated for cause. For each instance, identify an owner’s representative with a current phone and e-mail address and, if available, fax number.



- c. **Legal Proceedings** – Provide a list and a brief description, including the resolution of each arbitration, litigation, dispute review board, enforcement proceeding resulting in assessment of monetary penalty, fine or criminal penalty, and other dispute resolution proceeding involving Proposer or Equity Member or its parent company; its subsidiary companies; any company under joint ownership with such firm; any joint ventures or limited liability companies in which such firm is a member; and any partnership in which such firm is a general partner and involving an amount in excess of \$1,000,000 related to performance in trainset supply and/or maintenance projects or compliance with any environmental law with a contract value in excess of \$25 million.

Environmental, Socioeconomic, and Governance Policies (ESG)

The Proposal shall contain information on the Proposer's ESG efforts, which may include any environmental sustainability efforts, socio-economic equity policies, and governance policies, or a report that conforms to one of the following frameworks:

- i. ISO 2600-2010 Guidance on Social Responsibility;
- ii. Global Reporting Initiative Sustainability Report;
- iii. Organization for Economic Co-Operation and Development Guidelines for Multinational Enterprises;
- iv. UN Global Compact: Communication of Progress; or
- v. Other framework related to ESG; i.e.: Sustainability Accounting Standards Board, Task Force on Climate-Related Financial Disclosures, CDP, etc.

Please be advised that actual copies of ESG effort-related documents are not required to be submitted with the Proposal.

For purposes of this requirement, "socio-economic equity" means making opportunities and benefits available to all applicants, employees, and affected community members regardless of socioeconomic status and decision making that balances the effects of decisions on vulnerable and underserved communities and individuals regardless of income, race, ethnicity, age, gender, or other factors.



6.5 Volume 1B – Financial Information

The Authority seeks Proposers with the financial capability to deliver the Project successfully to reduce financial and delivery risks such that the plan and timetable is not impacted.

The Authority will evaluate the financial capability of the Proposer, Equity Members, and Guarantors (if any), based on review of the Financial Information provided in Volume 1B. Financial capability will be evaluated on the extent to which the financial metrics of the Proposer, Equity Members, and Guarantors, as applicable, demonstrate adequate financial capacity to deliver the Work.

The evaluation analyzes the Proposer’s credit rating, financial statements, and other financial information against the criteria below. The evaluation will consider that Proposers may have materially different business models, capital, and ownership structures, and where relevant to financial capacity, this may be considered in the evaluation of the Proposer’s, Equity Members’, and Guarantors’ ability to deliver the Project.

Volume 1B of the Proposal will contain the Financial Information. The required contents and organization of Volume 1B are set out in this Section. Each Proposer shall submit one (1) original and three (3) copies (for a total of four) of Volume 1B. The original must be clearly marked “Original” on its face and spine. Each copy must be numbered 1 through 3 on its spine. Proposer shall provide the following information in Volume 1B, as applicable:

Financial Capacity Criteria	Example of Financial Metrics	Maximum Score
Credit Rating (if applicable)	Rating provided by a nationally recognized rating agency (e.g., S&P, Fitch, or Moody’s)	10
Profitability	Revenue growth, EBITDA growth, gross profit margin, operating margin, net income margin, return on equity, sources of revenue or financial support	10
Liquidity	Current ratio, quick ratio	10
Leverage	Interest coverage ratio, net assets to debt, debt-to-equity ratio, debt profile	10
Performance	Accounts receivable turnover, days of outstanding payables, inventory turnover, working capital, asset utilization	10



Other Material Financial Matters	Recent Changes, off-balance sheet liabilities, legal matters, recent events, material obligations and contracts, assessment of Guarantor and its guarantee	10
----------------------------------	--	----

Each financial metric listed above will be assessed on a scale of 0 to 10 points based on the Proposer's financial capability against each of the above criteria. The Proposer must achieve a total minimum score of 30 otherwise the Proposer will be deemed non-responsive and will fail the evaluation.

In addition to the above, Proposers shall provide the following information in Volume 1B, as applicable:

Recent Financial Statements – The Proposal must include Financial Statements in accordance with the following requirements:

- a. **Format** – Three hard copies, one electronic copy in Portable Document Format (PDF) format, and one electronic copy in Microsoft Excel format.
- b. **Certification** – A statement from the CFO, CEO or Treasurer of the Proposer, Equity Member, or Guarantor, as applicable, stating that Financial Statements have been issued, either as year-end or interim Financial Statements, for its respective entity.
- c. **GAAP** – The Financial Statements must be prepared in accordance with U.S. Generally Accepted Accounting Principles (U.S. GAAP) or International Financial Reporting Standards (IFRS). If Financial Statements are prepared in accordance with accounting principles other than U.S. GAAP or IFRS, a letter must be provided from a certified public accountant discussing the areas of the Financial Statements that would be affected by a conversion to U.S. GAAP or IFRS.
- d. **U.S. Dollars** – Financial Statements must be provided in U.S. dollars. If Financial Statements are not available in U.S. dollars, the Proposer must include summaries of the Financial Statements for the applicable time periods converted to U.S. dollars, specifying the conversion rate used.
- e. **Audited** – For year-end Financial Statements, the Financial Statements must be audited by an independent party qualified to render audit opinions (e.g., a certified public accountant). If audited Financial Statements are not available for an entity, the Proposal shall include unaudited Financial Statements for each entity, certified as true, correct, and accurate by the CFO, CEO or Treasurer of the entity.



- f. **English** – Financial Statements must be prepared in the English language. If audited Financial Statements are prepared in a language other than English, translations of all Financial Statements must be provided with the original Financial Statements.
- g. **Newly Formed Entity** – If the Proposer is a newly formed entity and does not have Financial Statements, Financial Statements for the equity owners of the newly formed entity must be provided and the Proposer shall expressly state that the Proposer is a newly formed entity and does not have Financial Statements.
- h. **SEC Filings** – If any entity for which Financial Statements are submitted files reports with the Securities and Exchange Commission, then such Financial Statements shall be provided through a copy of its annual report on Form 10K and any subsequent reports filed on Form 10Q or Form 8-K.
- i. **Credit Ratings** – The Proposal must include a copy of the credit rating for the Proposer, any Equity Member, or Guarantor.

Guarantor Letter of Support – If the Proposer or any Equity Member includes a Guarantor as part of its submission, then the Proposal shall include a letter from each Guarantor stating that it will provide a performance guaranty in the form as set forth in Section 7 of the TSCC Agreement and that it will financially support all the obligations of the Proposer with respect to the Project. In addition, if the Proposer is offered the opportunity, at the sole discretion of the Authority, to add a Guarantor to its Proposal in accordance with Section 6.5, then the Proposal shall include a letter from the additional Guarantor stating that it will provide a performance guarantor as set forth in section 7 of the TSCC Agreement and that it will financially support all the obligations of the Proposer with respect to the Project.

6.6 Volume 2 – Executive Summary and Technical Proposal

Volume 2 of the Proposal will contain the Executive Summary and Technical Proposal. The required contents and organization of Volume 2 are presented in this Section. Each Proposer shall submit one original and five printed copies (for a total of six) of Volume 2. The original must be clearly marked “Original” on its face and spine. Each copy must be numbered 1 through 5 on its spine. Each Proposer shall further provide a digital copy of Volume 2.



The Proposer shall not include any information regarding Proposal price in dollar amounts in any of the materials submitted as part of Volume 2.

6.6.1 Executive Summary

The Executive Summary shall contain sufficient information to familiarize reviewers with the Proposer's Project approach and its ability to satisfy the legal requirements of the Contract. The Proposer shall limit the Executive Summary to no more than 10 pages inclusive of text, selected photographs, and sketches. The Executive Summary page count is not counted toward the page limit requirement of the Technical Proposal. The Proposer shall highlight those items which, in the opinion of the Proposer, represent significant value to the Authority and which may distinguish its Proposal from those of others.

At a minimum, the Executive Summary shall include the following:

- a. **Legal** – A description of the Proposer's form of organization, identification of the lead entity, the percentage of interest held by the Equity Members, and all entities that will have joint and several liability for the Contract or that will provide Guaranties (if required) to the Authority. All entities identified in the Executive Summary must be identified by their full and correct legal names.
- b. **Technical** – A description of the Proposer's understanding and approach to the Work, including procurement, construction, and coordination with third parties (including Interfacing Contractors). Include a summary of (i) how the Proposer intends to deliver construction solutions that are efficient, schedule-sensitive, environmentally compliant, durable, safe and maintainable; and (ii) the Project support concepts to be addressed in connection with the Work including support of public outreach, coordination with adjacent contracts and concepts for mobilization, delivery of materials and mitigation of traffic and other impacts during construction; and (iii) demonstration of relevant experience and lessons learned working in collaborative contract environments.
- c. **Financial** – Information regarding the Proposer's financial strength and capability to undertake and complete the Work, including any other relevant information regarding the Proposer's financial approach to completing the Work and assuming the risks allocated to the TSSC Contractor under the Contract.



6.6.2 Technical Proposal

The Proposal shall include a Technical Proposal describing the Proposer's approach to management oversight, design development and integration for systems design, schedule and construction integration, safety and security management, interface management, certification, procurement and an outline of means and methods for construction and testing that shall contain the proposers approach to meeting the criteria described in this section and scored as per the scoring in Attachment B. The Technical Proposal shall be consistent with the requirements of the Contract. The Technical Proposal shall be no more than 100 pages in length; the 100 page-limit, however, does not include the Executive Summary, Schedules, resumes for Key Personnel, forms, sketches, renderings, and drawings. Index tabs and any cover pages will not be counted toward the page limits provided they do not include any substantive content. Any pages included beyond these limits will be disregarded and not evaluated.

The Technical Proposal shall demonstrate that the Proposer has a clear understanding of the Work, and how the Work integrates into the overall Project requirements. The Technical Proposal shall include identification of long lead procurement items and identification of any possible Buy America compliance issues. The Proposal shall also identify key risk and the Proposers mitigation plan to mitigate these risks.

The Technical Proposal will be used to evaluate Proposer knowledge of how the Work integrates with Interfacing Contracts as part of the Project, and to demonstrate Proposer technical knowledge of the procurement, construction and integration of Track, OCS, traction power, train control, telecommunications, and SCADA systems in a rail environment.

- a. **References** – The Proposer shall provide references for at least three, and no more than five, mega (\$1 billion or more) project clients. The following shall be represented in the references provided: project clients for whom the Proposer has performed design, construction, integration, testing, and commissioning work of high-speed rail projects or railroad projects; and projects delivered utilizing a collaborative delivery model in support of the past experience provided in response to Section 6.6.2(a) of this RFP.

The following contact information for each reference shall be included: (i) the name of the client; (ii) the title of the project or assignment; and (iii) current contact phone numbers and email addresses for the client.

References shall be for:



1. The prime contractor, if a single entity is the prime contractor submitting the Proposal.
2. The joint venture as a whole, if the Proposal is submitted by a joint venture that has worked together in the past.
3. Each prime member of the joint venture, if the Proposal is submitted by a joint venture that has not worked together in the past.
4. Any Subcontractor employing Key Personnel, if applicable. In such a case, include one additional reference for each applicable Subcontractor.

b. Reference Projects

For each reference project identified along with the Proposer's references, the Proposer shall include the following information:

1. The scope of the project, including its delivery model;
2. The name of the Proposer Team member that worked on the project;
3. The start and end dates of the Proposer Team member's work on the project;
4. Original schedule and budget for the project, and final schedule and budget upon completion;
5. A summary statement for the project; and
6. Examples of collaboration with the owner to provide innovative approaches that contributed to project quality and/or cost or schedule savings (if any).

c. Understanding of the Contract and Delivery Approach

The Authority intends to contract with a Proposer team with a strong understanding of the requirements for the Work included in the Scope of Work described in Schedule 16 to the TSCC Agreement, and the requirements for its successful management. The Proposer should include a discussion of the understanding of the Contract and delivery approach. The Proposer is expected to include a discussion of its understanding of the unique elements of the Contract structure. The narrative should also include a discussion of the Proposer's technical and project management skills necessary to deliver the Contract, and how the Proposer team adds value and works toward the goal of achieving optimal efficiency for delivering the Work.



d. Proposer Team, Organization, and Management Approach

The Authority intends to contract with a Proposer team with organizational and staffing plans that are appropriate for Work and with experienced personnel in key roles.

Proposers are advised to describe the composition of the Proposer team, and how activities are assigned. In the Technical Proposal, Proposers shall:

- Include how a clear plan for mobilization, including the relocation of key personnel to the Central Valley as well as the process for mobilizing relevant staff at the beginning of the to deliver the Work.
- Submit an organization chart indicating specific personnel nominations for primary and technical support positions, including proposed Key Personnel.
- Discuss how the organization and management plan will allocate sufficient and appropriate resources to deliver the Project, and how the organizational and management approach will evolve over the life cycle of the Project.
- Describe how the organization will integrate with Authority staff and how it will work collaboratively with the Authority and Interfacing Contractors throughout the life cycle of the Project.
- Describe approach to providing maintenance of the Project during construction and once testing is complete.
- The Proposer shall provide a general discussion of the expected Work elements based on the activities described in the Scope of Work in Schedule 16, including how the Proposer plans to achieve the requirements in the Scope of Work.
- The Proposer should discuss how each Key Personnels past experience relates and will be applied to achieve the requirements in the Scope of Work.
- The Proposer shall identify all known Subcontractors on Form F (Schedule of Subcontractors) Form F is to be submitted with the Administrative Volume.
 - Letter of Commitment - For Work which will be accomplished by a Subcontractors(s), the Proposer shall include a letter of



commitment from the proposed Subcontractor(s), which shall include: the point of contact for the Subcontractor; the classifications or position titles; State licensing requirements for the job classifications or positions; and names, including any licenses and license numbers, of personnel in each job classification or position that will be made available for the Work as necessary to meet time frame performance requirements.

- Letters of Commitment should be attached to the Transmittal Letter. They shall be limited to 2 pages and will not be included in the Technical Proposal 100-page limit.
- The Proposer shall provide a time-phased staffing plan showing all positions needed to accomplish the various types of assignments for the duration of the Contract. The plan should indicate the level of participation for each position by giving the percentage of hours budgeted over calendar time. The plan shall indicate proposed staffing locations for all staff across all stages of the Work, as applicable to the Work.

The staffing for the Contract resulting from this RFP may be updated and approved as required by the Contract or as requested by the Authority.

e. Key Personnel Past Experience and Roles

The Authority seeks a Proposer team that includes personnel with knowledge of applicable standards, regulations, codes, technology, technical skills, and qualifications to perform the Work, particularly skills related to delivery of high-speed rail projects, development and delivery of relevant rail systems (including but not limited to ETCS Level 2, OCS, UIC60 track, communications systems, and traction power), and complex project delivery through CMGC, CMAR, PDB or similar collaborative contracting methods.

All Key Personnel shall submit a signed statement indicating that they understand the project office will be located in either Sacramento or in the Central Valley of California and are willing to work full time at that location as determined by the work schedule and the requirements of project.

The Proposal must include information regarding California professional or other licenses held by the Proposer's Key Personnel. Where the Work requires a professional license, at least one Key Personnel in responsible charge of the Work (subject to the Professional Engineers Act) shall be a



California registered Professional Engineer in good standing by the date of Contract execution.

Resumes, up to three pages, shall be provided for the primary team members and all Key Personnel listed on the Key Personnel Matrix (Form E). Key Personnel Resumes are to be submitted with the Transmittal Letter in Volume 1A.

The Proposer should provide a list of individuals who will fill the following Key Personnel positions:

f. Key Personnel Qualifications

1. **Principal In Charge** – The Principal In Charge has overall responsibility for track, systems, integration, cost, schedule, safety, and quality obligations for delivery of the Work. This person has responsibility for the delivery and administration of all design integration, procurement, stakeholder coordination, construction, testing and commissioning activities for the duration of the Contract and is responsible for the Work being delivered safely and within time and budget. The person nominated for this role should have at least 20 years' experience in the delivery of railroad projects within a multidisciplinary environment. Proposer shall provide the following information for the mega projects referenced by the Principal In Charge: total value of the Contract at award, final value of the Contract at Contract close, original completion date and final completion date, and number of claims, if any.
2. **Construction Manager** – Responsible to manage the day to day operations and coordination with the Authority Construction Manager in all aspects of the Contract and delivery thereof. This position should be proficient in managing Alternative Delivery contracting, with experience leading and supporting a collaborative management style and demands this of their team, experience in managing in excess of a billion dollars in contracts with major components of rail; high-speed rail is preferred, but not required. Experience managing systems installation and coordination with track and OCS installation. Will report daily to the project site in the Central Valley. This position should demonstrate the ability to work collaboratively with the Authority.
3. **Engineering and Design Director** – The Engineering and Design Director is responsible for all engineering oversight and management



within the Contractors' project organization. This person is responsible for coordination between the Contractor's design, construction, and testing teams, interface with the Track/OCS Design Services Consultant, interface with Interfacing Contractors and Interfacing Railroads and is responsible for the oversight of all subcontracting organizations. The person nominated for this role should have a minimum of 20 years of progressive experience leading all engineering activities within a Contractor's organization for the successful delivery of complex, multidisciplinary rail systems projects, including previous high-speed rail delivery experience. Proposer shall list high-speed rail projects referenced by the Engineering and Design Director and their final value.

4. **Design Oversight Manager** – The Design Oversight Manager is responsible for the interface with the Track/OCS Design Consultant's organization(s) and preparation of the preliminary design for systems. The person nominated for this role should have a minimum of 15 years of progressive experience leading design organizations for the successful delivery of complex, multidisciplinary rail systems projects, including previous high-speed rail design experience. The Design Manager shall be a registered professional engineer in the State of California.
5. **System Integration Manager** – The System Integration Manager is responsible for the specification, control, implementation and testing (where applicable) of all interfaces, including, but not limited to, interface with the Track/OCS Design Consultant, interface with Interfacing Contractors and Interfacing Railroads and Third Party Organizations and is responsible for the interface oversight of all subcontracting organizations. The person nominated for this role shall have a minimum of 10 years of experience leading Interface management activities for installation organizations for the successful delivery of complex, multidisciplinary rail systems projects, including previous high-speed rail installation experience.
6. **Safety, Security, and Certification Manager** – The Safety, Security, and Certification Manager is responsible for overseeing and managing the system safety and certification aspects of the Contractors activities for the duration of the contract. This individual shall ensure project compliance with regulations and standards, establish an appropriate



system safety framework, interface with regulators to ensure program compliance and develop the safety case elements for the Contractors works. The person nominated for this role should have a minimum of 15 years of experience leading safety and certification activities for complex, multidisciplinary rail systems projects.

7. **Track & OCS Installation Manager** – The Track & OCS Installation Manager is responsible for the management oversight of the installation of all Track and OCS Systems, and will oversee the execution of all installation works required to satisfy program objectives. The Track & OCS Installation Manager shall be responsible for the management oversight of all installation personnel and resources. The person nominated for this role shall have a minimum of 15 years of experience overseeing installation organizations for the successful delivery of complex, multidisciplinary rail systems projects, including previous high-speed rail installation experience.
8. **Traction Power System (TPS) Manager** – The TPS Manager is responsible for the design management and oversight of the TPS, with a comprehensive understanding of design, manufacturing, construction, installation, testing, and commissioning of the TPS and coordination with stakeholders. The person proposed for this role shall have a minimum of 15 years of experience with the successfully delivering complex, multidisciplinary rail systems projects, including previous high-speed rail experience.
9. **Communication Manager** – The Communication Manager is responsible for the design management and oversight of the Communication System, with a comprehensive understanding of design, manufacturing, construction, installation, testing, and commissioning of the Communication System and coordination with stakeholders. The person proposed for this role shall have a minimum of 15 years of experience successfully delivering complex, multidisciplinary rail systems projects, including previous high-speed rail experience.
10. **Train Control Manager** – The Train Control Manager is responsible for the design management and oversight of the Train Control System, with a comprehensive understanding of design, manufacturing, construction, installation, testing, and commissioning of the Train



Control System and coordination with stakeholders. The person proposed for this role shall have a minimum of 15 years of experience successfully delivering complex, multidisciplinary rail systems projects, including previous high-speed rail experience.

11. Civil/Structural Integration Manager – The Civil/Structural Integration Manager shall have experience in major rail or high-speed rail civil/structural works. The role leads all interfaces between the Track and Systems Works and the existing civil infrastructure—viaducts, bridges, tunnels, retained cuts, embankments, drainage, utilities, and station structures. The Civil/Structural Integration Manager ensures all track, OCS, traction power, signaling, and communications installations are fully compatible with high-speed structures, including requirements for clearances, dynamic behavior at high-speed, load paths, deflection limits, seismic performance, and structural capacity for systems loads. The role coordinates field verification, identifies and resolves civil/systems interface issues, confirms suitability of as-built structures, and ensures that all structural assessments, modifications, and approvals meet Authority requirements and are signed and sealed in accordance with California PE regulations.

12. Digital Manager – The Digital Manager shall lead all digital engineering activities for the TSCC Works, with primary responsibility for BIM delivery, cyber security data specifications, and digital integration of the train control and systems assets. The role manages the Contractor’s Common Data Environment (CDE), ensures compliance with Authority BIM and CAD Standards, Asset Information Requirements, GIS specifications, and all digital data requirements for signaling, ETCS, telecoms, SCADA, traction power, cyber security, and OCS. The Digital Manager shall oversee the creation, federation, and quality of BIM models and structured data, ensuring all system components—train control equipment, cabinets, lineside assets, fiber routes, OCS supports, TPSS assets, and interfaces with civil structures—are accurately represented and coded. The role ensures all digital submissions, metadata, and asset data sets meet Authority specifications, support system integration, clash detection, testing and commissioning, and are fully verified for digital handover.

13. Supply Chain Manager - The Supply Chain Manager is responsible for the management and oversight of the procurement of all Track and



OCS Systems (including subsystems, assemblies, parts, materials, components, and the OEM procurement), and will oversee the execution of all procurement efforts required to satisfy program objectives. The Supply Chain Manager shall be responsible for the management of all procurement personnel and resources. The person nominated for this role shall have a minimum of 10 years of experience leading the procurement for the successful delivery of complex, multidisciplinary rail systems projects, including previous high-speed rail installation experience.

g. Understanding of Project Elements and Requirements

The Proposer shall provide a narrative demonstrating the Proposer's understanding how the work requirements and approach to delivery of the Project, including laying track, completing the work described in NTP 1 as quickly as possible. Proposer's narrative shall also describe the planned staging and scheduling of the work, as well as management of workforces needed, to ensure completion of construction for the 119-mile First Construction Section within the Project Schedule.

Proposer shall provide a draft Project schedule showing mobilization, construction of track and OCS work, design and construction of Systems work, testing, and commissioning, for the 119-mile First Construction Section within the Project Schedule.

h. Traction Power, Train Control and Communications Systems Approach

The Proposer shall provide a narrative demonstrating the Proposer's approach to delivery of the Systems Work, including:

- Preliminary design preparation;
- Process for procurement of the OEM to ensure receipt of Proposals by at least two qualified proposers using a best value method;
- Specific schedule and deliverables for the OEM procurement, including dates for completing preliminary design, issuing the RFP, and points in engaging the Authority for review and approval during the process
- Design management and completion of the systems design with the OEM;
- Process for developing the pricing of the systems, including how Proposer will ensure that pricing involves a collaborative, transparent



open-book process leading to a reasonable and acceptable price for the Authority; and

- Approach to construction management and oversight of the OEM.

Proposer shall include past experience in managing the OEM and Systems Work to successfully deliver projects on-budget and on-schedule and manage integration and coordination.

Proposer's draft Project schedule shall include a draft schedule for delivery of the Systems work to achieve the Project completion deadlines.

i. Risk Management and Integration Approach

The Proposer shall provide a narrative demonstrating the Proposer's approach to risk management and integration to facilitate successful delivery of the Project. Proposer's approach shall address the following:

- Key risks, challenges, and opportunities related to the Project;
- Proposer's approach to risk mitigation, contingency pricing, and risk management for the Project;
- Describe specifically how the Proposer's team will work collaboratively with the Authority to identify and mitigate risk.
- Proposer's processes and approach for management and inclusion of Authority-provided materials into the Work, including quality management, management of quality issues, if detected, acceptance, integration, and integration with Project schedule and budget; and
- Systems integration requirements among the track, OCS, and systems scopes of work, including tools and software you will use to manage systems integration for the Project.

The Proposer shall also describe specifically how the proposer intends to bring innovation, collaboration and experienced team members to bring cost and schedule certainty and deliver this Project on time and on budget.

j. O&M Phase Benefits

The Proposer shall provide a narrative on the following to demonstrate the O&M phase benefits of its approach to the Work.

Proposer's narrative shall describe the approach to designing the system components of the Project to minimize O&M and lifecycle costs, including innovative strategies and methods to enhance rail operations.



Proposer shall also describe how the Proposer's approach to construction enhances rail operations, increases efficiency, and minimizes O&M and lifecycle costs throughout the useful life of the Project.

k. Small Business Participation and SB Performance Plan

The Authority's SB Program is in compliance with the Best Practices of 49 C.F.R. Part 26, California Executive Orders S-02-06 and D-43-01, Government Code §§ 4532-4535, 11148.5, 12098.4, and 14835-14846 Executive Order S-02-06, Military and Veterans Code 999 and Title VI of the Civil Rights Act of 1964 and related statutes. The SB Program establishes a 25 percent SB, inclusive of a 3 percent goal for MB utilization that is calculated based on total contract dollars received from state funds, including all future amendments that increase and/or decrease the contract value.

Under all contracts that receive federal funds, there is an additional 10 percent utilization goal for DBE. If a contract receives only federal funds, this utilization goal for DBE increases to 17%.

Under all contracts that receive state or federal funds, there is an additional 3 percent utilization goal for DVBE.

As part of the Technical Proposal, the Proposer shall submit a general description of how it will meet the Authority's Small Business Goals. In addition, the Proposer is expected to present a narrative (SB Performance Plan) detailing how it will utilize SB/MB/SB-PW/DBE/DVBEs throughout the life of the Contract. The Proposer shall identify firms being utilized to meet the SB Program goals, including the estimated contract values and scopes of work that will be used to meet these goals.

The successful Proposer shall comply with all SB Program requirements, including, but not limited to, SB utilization reporting, substitution/termination processes, and other performance related factors as identified in the SB Program. The Proposer should refer to the SB Program and the Prompt Payment Act provisions that will apply to any contract resulting from this procurement. Proposers should be advised that at contract closing, all DVBE data shall be accurately completed on the Prime Contractor's Certification DVBE Subcontracting Report (STD 817). The Authority shall withhold \$10,000, or full payment if less than \$10,000, from a prime contractor's final payment pending receipt of a complete and accurate STD 817 (Military and Veterans Code § 999.5(d), 999.55, 999.7(a)).



Each listed certified SB, MB, SB-PW, DBE, and DVBE must perform a CUF in the performance of the Contract as defined in Government Code section 14837(d)(4) and the SB Program.

The SB Program will be incorporated by reference into any contract resulting from this procurement. The Proposer is advised to read and become familiar with the [SB Program](#).

See [Policy & Program Plan - California High Speed Rail](#)

I. Small Business Communication Plan

Additionally, the SB Performance Plan shall contain a separately titled section that contains a description of how the Proposer intends to meet the requirements of the Communication Plan as described in Section 3.16 of the ITP.

The Communication Plan shall relay the Contractor's commitment to monthly reports to the Authority that document communication to SB/DB/DVBE subcontractors regarding schedule, deadlines, status, and delays.

6.7 Volume 3 – Price Proposal

Volume 3 of the Proposal will contain the Price Proposal, which is comprised of: (1) Form J1 (Proposed Table of Rates and Prices) and (2) Form J2 (Price Proposal Summary).

The required contents and organization of, and other requirements related to, Volume 3 are presented in this Section 6.7. The Price Proposals shall be submitted in a separate, sealed envelope and will remain sealed in a secure location until after the Pass/Fail and Technical Proposal review.

a. Format

Proposers must submit Form J1 (Proposed Table of Rates and Prices) in three (3) formats: (i) an electronic Microsoft Excel (.xlsx) spreadsheet – a fully functional, editable version created using Excel 2016 or a more recent version (English, United States) that does not rely on any external modules or data; (ii) an electronic Portable Document Format (.pdf) – a static version of the Microsoft Excel spreadsheet, showing all worksheets and tabs in a searchable printed-page layout; and (iii) one (1) printed, hard-copy version of the electronic .pdf file. Two copies of the electronic formats of Form J1 must be provided, each on a separate USB drive. If there is any discrepancy between the three formats of Form J1, the hard-copy format will govern.



Proposers must submit one (1) printed, “ORIGINAL” signed hard-copy of Form J2 (Price Proposal Summary) and an electronic copy included in each separate USB drive with electronic copies of Form J1.

b. Form J1 (Proposed Table of Rates and Prices) Instructions

Proposers must complete the Form J1 (Proposed Table of Rates and Prices) template, which has been provided as an electronic Microsoft Excel (.xlsx) spreadsheet, in accordance with the following instructions:

1. TSCC Contractor Fee tab:

- a. Input the proposed profit margin the Proposer will apply to self-performed Design Work. The profit cannot exceed 10% and a Proposal will be deemed non-responsive if the proposed profit exceeds this maximum percentage.
- b. Input the proposed profit margin the Proposer will apply to Subcontractors’ Design Work. The profit cannot exceed 10% and a Proposal will be deemed non-responsive if the proposed profit exceeds this maximum percentage.
- c. Input the proposed profit margin the Proposer will apply to self-performed all other Work. The profit cannot exceed 14% and a Proposal will be deemed non-responsive if the proposed profit exceeds this maximum percentage.
- d. Input the proposed profit margin the Proposer will apply to Subcontractors’ all other Work. The profit cannot exceed 10% and a Proposal will be deemed non-responsive if the proposed profit exceeds this maximum percentage.
- e. Input the TSCC Contractor’s Overhead on all Work as a percentage.
- f. Sum up the profit and overhead for the respective TSCC Contractor Fee according to Form J.

Description of Overhead for TSCC Contractor Fee tab

For Overhead in the TSCC Contractor Fee tab, Overhead shall include all indirect cost items, including applicable taxes, employee benefits, insurance payments, parental leave, medical leave, family leave, disability benefits, bonuses, overtime pay, premium pay, parking and car allowance, fringe benefits, retirement plans, union dues, contributions, and assessments required by Law and collective bargaining, as well as corporate general and administrative expenses, such as corporate management oversight, accounting, information technology, and legal services, to the extent allowable,



allocable, and reasonable in accordance with 48 C.F.R. Part 31 and 2 C.F.R. Part 200, as applicable (and not payable as a Direct Cost)

Do not include compensable project costs in the overhead in the TSCC Contractor Fee tab. Compensable project costs are a Direct Cost (e.g., General Requirements) and will be negotiated for each Package according to Schedule 23A. Examples of compensable project costs for Packages include, but are not limited to, the following:

- Project management and supervision
- Office and office expenses
- Quality control
- Safety
- Surveying
- Yard and yard maintenance
- Taxes, licenses, permits, and fees
- Insurance and bonds
- Maintenance during construction
- Security and losses

2. Precon/PM Work & Package 1B

- a. Input the labor rates of proposed staff for Precon/PM Work (described in Schedule 23A of the Agreement) and Package 1B. Labor rates should be Fully Loaded Rates (as defined in the Agreement).
- b. Proposed staff should be identified with proposed role or classification, firm, and Prime/Subcontractor.

3. Package 2:

- a. Input the estimated Direct Costs of the Work defined in Package 2 of Schedule 16 of the Agreement into the Package 2 tab to calculate the total Direct Costs for the Package. These Direct Costs of the Work will be subject to modification according to Section 10.9.1 and Schedule 23 of the TSCC Agreement. *[Note to Proposers: the scope and Direct Costs of the mobilization Work for Package 2 is now included in the scope of Package 2]*



- b. Using the applicable margins included in the TSCC Contractor Fee tab, calculate the TSCC Contractor Fees for the Package.
- c. Sum the various amounts to calculate the price for the Package.
- d. Additional information and bid tab descriptions are provided in Attachment D to this ITP.

c. Form J2 (Price Proposal Summary)

Upon completion of Form J1 (Proposed Table of Rates and Prices), Proposers will be able to complete Form J2 (Price Proposal Summary) as a summary of the proposed prices and TSCC Contractor Fee percentages in Form J1 (Proposed Table of Rates and Prices). Proposers must complete the Form J2 (Price Proposal Summary), attached hereto, in accordance with the instructions therein. The submitted “ORIGINAL” hard-copy of Form J2 (Price Proposal Summary) must be signed by a duly authorized representative of the Proposer.

6.8 Escrowed Proposal Documentation

Each Proposer shall submit all documentary information generated in preparation of the Price Proposal. This requirement shall apply to information generated by the Proposer and by all Subcontractors. This documentary information is hereinafter referred to as “Escrowed Proposal Documents (EPDs).” Proposers shall submit the Escrowed Proposal Documents Certification (Cert. 16) with the EPD submittal, certifying to the accuracy of the information in the EPDs.

The EPDs shall contain information in accordance with section 24.6 of the TSCC Agreement regarding the Proposer’s assumptions made in calculating the prices included in the Price Proposal and identification of Tariff Material and calculation of Tariff Material Values. The Proposer shall submit its EPDs in such format as it used in preparing its Proposal. The EPDs shall be organized in a logical fashion to reflect the organization of the Price Proposal.

In the event that the Authority requests revisions to Proposals and BAFOs or one or more Proposers are asked to clarify its Price Proposal, each Proposer shall submit one copy of all additional documentary information generated in preparation of the Proposal revisions and BAFO or clarification (including Subcontractor pricing changes for Subcontractors). This additional documentation is considered as part of the EPDs.

EPDs shall be delivered to the Authority in a locked fireproof cabinet supplied by the Proposer. The cabinet shall be stored in the Authority’s offices or in another location designated by the Authority, with the key held only by the Contractor. EPDs shall be delivered prior to 4:00 p.m. (Pacific Time) on the third Working Day following the Proposal Deadline (see Table 1 in Section 3.1 of this RFP). Release of EPDs will be in accordance with the Contract.



Representatives of the Authority and the Apparent Best Value Proposer shall review the EPDs of the Apparent Best Value Proposer prior to Contract execution to determine whether they are complete and in compliance with section 24.6 of the TSCC Agreement. The purpose of this examination is to ensure that the EPDs are authentic, legible and complete. The Apparent Best Value Proposer shall correct any deficiencies to the EPDs within three days of discovery. The examination will not include detailed review of, and will not constitute approval of, proposed construction methods, estimating assumptions or interpretations of RFP Documents. Examination will not alter any condition or term of the Contract.

Representatives of the Authority and the Apparent Best Value Proposer shall also organize the EPDs, labeling each page so that it is obvious that the page is a part of the EPDs, and enable a person reviewing the page out of context to determine where it can be found within the EPDs. An index shall be compiled listing each document included in the EPDs and briefly describing the document and its location in the EPDs. The Authority shall have a right to retain a copy of the index.

The EPDs will be available for joint review by the Apparent Best Value Proposer and the Authority in conjunction with any pre-award or pre-execution discussions and negotiations. Following execution of the Contract, the EPDs of the Apparent Best Value Proposer will be available for joint review as specified in the Contract.

EPDs for each unsuccessful Proposer will be available for collection after the Contract is signed with the successful Proposer. EPDs for all Proposers will be available for collection if all Proposals are rejected or withdrawn.

6.9 Stipend Payment

The Authority will make a payment for costs of preparation of the Proposal of \$1 million to each Proposer that identified their intent to seek the stipend, executes a Stipend Agreement in the form provided as Form Q (8 pages), by the deadline provide in Table 1 and then submits a responsive Proposal by the RFP Proposal Deadline set forth in Table 1, RFP Schedule.

If the Authority cancels this procurement, the Authority will make a payment for proven costs of preparation of the Proposal, up to \$1 million, to each Proposer who delivers an executed Stipend Agreement in the form provided as Form Q by the deadline provided in Table 1.

Any such payment shall be subject to the terms and conditions contained in the Stipend Agreement. This offer of payment entitles the Authority to use work product and ideas contained in any unsuccessful Proposal submitted for the TSCC. The Authority acknowledges that the use of any of the work product by the Authority or the successful Proposer is at the sole risk and discretion of the Authority and the successful Proposer and shall in no way be deemed to confer liability on the unsuccessful Proposer. All



parties acknowledge that the due date for payment for work product will occur after the execution date of the Contract or cancelation of this procurement.

7 Evaluation and Negotiation

The Authority may reject any Proposal if it is conditional, incomplete, or contains irregularities. The Authority may waive an immaterial deviation in a Proposal or any portion of any required submittal. The Authority reserves the right, at its sole discretion, to request clarifications regarding information contained in any Proposal or any portion of any required submittal. Waiver of an immaterial deviation shall in no way modify the RFP documents or excuse the Proposer from full compliance with the Contract requirements if the Proposer is awarded the Contract as a result of this procurement.

The following summarizes the Proposal Review, Evaluation, and Negotiation processes.

7.1 Proposal Review

The Authority shall review and evaluate each Proposal and required submittals to determine if they meet the requirements contained in Section 6 and in Form A through Cert. 16. Failure to meet the material requirements of this RFP will result in the rejection of the Proposal. Proposals and required submittals that contain false or misleading statements, or which provide references which do not support an attribute or condition claimed by the Proposer, may be rejected.

7.2 Proposal

The Authority shall evaluate and score Proposals that meet the RFP requirements. The Evaluation/Selection Committee will evaluate Proposals based on the criteria described in this RFP, including Attachment B, and determine a consensus score for each criterion. The Authority may consider any and all required submittals as part of its review and evaluation of Proposals.

7.3 Proposer Minimum Qualifications

The Proposer must submit all of the required information as described in Section 6 of this RFP. All of the information identified must be included for the Proposal and required submittals to be considered responsive. Proposals or required submittals with missing or incomplete information may be rejected. If a Proposer passes this phase, its Proposal will be evaluated and scored.



7.4 Price Scoring

The Price Proposal will be scored out of 70 points. The Price Score will be determined as follows:

Price Score is equal to the sum of:

- a) (Lowest Proposer's Package 2 Price / Proposer's Package 2 Price) x 35;
and
- b) (Lowest Proposer's TSCC Contractor Profit score / Proposer's TSCC Contractor Profit score) x 35
 - a. Whereas Proposer's TSCC Contractor Profit score equals:
 $(\text{Proposer's TSCC Contractor Profit on self-performed other Work} * 45) + (\text{Proposer's TSCC Contractor Profit on subcontracted other Work} * 45) + (\text{Proposer's TSCC Contractor Profit on self-performed Design Work} * 2) + (\text{Proposer's TSCC Contractor Profit on subcontracted Design Work} * 8)$

The Price Proposals will remain in a secure location until after the Minimum Qualifications check (Section 7.3) has been completed and the Technical Proposal has been evaluated and scored.

7.5 RFP Revisions and BAFOs

The Authority reserves the right to declare a competitive range of one or more Proposers, having engaged in communications with Proposers or not; engage in discussions with Proposers in the competitive range; revise the RFP, if necessary; and request Proposal revisions and/or BAFOs from the competitive range of Proposers, though it is under no obligation to do so. If the Authority issues RFP revisions and requests BAFOs, Proposers will be informed and requested and/or allowed to revise their Proposals in accordance with the terms of the RFP revisions and/or requested Proposal revisions/BAFOs. Proposers may be required to submit written acknowledgement of the RFP revision/BAFO request prior to submittal of the Proposal revision/BAFO. The Authority will consider the revised information submitted as part of the Proposal revision/BAFO process and reevaluate and revise ratings as appropriate.

In the event that any Proposer requested by the Authority to submit Proposal revisions/BAFOs fails to provide a Proposal revision/BAFO, or delivers a Proposal revision/BAFO that is deemed unacceptable or late, the Authority shall have the right to consider as valid such Proposer's initial or subsequently revised Proposal and to award the Contract to such Proposer based on its initial or subsequently revised Proposal.



All terms and conditions of these Instructions to Proposers applicable to Proposals shall also be applicable to Proposal revisions/BAFOs except as otherwise specified in the RFP revision, request for Proposal revision, and/or BAFOs.

7.6 Final Scoring

Once the final score is set, the Authority's Evaluation/Selection Committee will recommend the Proposer with the highest final score to the Authority's Chief Executive Officer/Executive Director (CEO) for contract award.

7.7 Notice of Proposed Award

After the Proposer with the highest final score is determined, the Notice of Proposed Award (NOPA) will be posted in the Authority's Sacramento Office at 770 L St. St 620, Sacramento, CA 95814 for a minimum of five Business Days and on the Authority's [website](#).

A courtesy copy of the Notice of Proposed Award will be provided to all Proposers via email.

7.8 Contract Negotiation Process

The Authority will enter into limited negotiations with the top-ranked Proposer. If limited negotiations are unsuccessful, the Authority will terminate all negotiations with the top-ranked Proposer and enter into limited negotiations with the next highest ranked Proposer and so on sequentially.

Upon approval by the Authority Board, the Authority will be authorized to award and execute the Contract to the selected Proposer.

7.9 No Contract Until Signed and Approved

No Contract between the Authority and the successful Proposer is in effect until the Contract is signed by the Contractor and signed by the Authority.

Additionally, prior to execution of the Contract, the successful Proposer must complete the Authority's Affordable Care Act (ACA) questionnaire (as required by federal law), if applicable. No Contract between the Authority and the successful Proposer is in effect until the Contractor returns the completed ACA questionnaire.

7.10 Debriefings

After the Notice of Proposed Award is posted, each Proposer may request a debriefing with the Authority's Designated Point of Contact. The meeting should



be requested within 10 Business Days from the date of the Notice of Proposed Award. The debriefing meeting is an opportunity for Proposers to receive feedback regarding their own Proposals and Discussion performance, which may provide insight for use in future solicitations. Debriefings will be held after the procurement process ends when the Contract has been executed.

7.11 Confidentiality

The successful Proposer awarded a Contract as a result of this RFP shall be required to maintain the confidentiality of any information it obtains in the course of performing services under the Contract, and shall hold the Authority harmless from any claim, loss, or liability resulting from the successful Proposer's disclosure of such information. The confidentiality obligations under the resulting Contract shall remain binding on both parties during the term of the Contract, and survive expiration, termination, and/or the end of the Contract, regardless of cause.

8 Protest Procedures

8.1 Applicability

This section sets forth the exclusive protest remedies available to Proposers with respect to this RFP and prescribes the exclusive procedures and timing requirements for protests regarding:

1. Allegations that the terms of the RFP are ambiguous, contrary to legal requirements applicable to the procurement, or exceed Authority's authority;
2. A determination as to whether a Proposal is responsive to the requirements of the RFP or the Proposal does not meet all Minimum Qualifications; and
3. Final selection.

8.2 Required Early Communication for Certain Protests

Protests concerning the issues described in Section 8.1(1) may be filed only after the Proposer has informally discussed the nature and basis of the protest with the Authority, following the procedures prescribed in this Section 8.2. Informal interviews shall be initiated by a written request for a one-on-one meeting delivered via email to the Authority's Designated Point of Contact provided in Section 3.1. The written request should include an agenda for the proposed one-on-one meeting. The Authority will meet with the Proposer as soon as practicable to discuss the nature of the allegations. If necessary to address the issues raised



in a protest, the Authority may make, in its sole discretion, appropriate revisions to the RFP documents by issuing addenda.

8.3 Deadlines for Protests

The failure of a Proposer to file a protest within the applicable period shall preclude consideration of those issues in any protest. If a deadline for a protest or any related filing falls on a weekend or State of California holiday, it shall be moved to the next Business Day.

Protests concerning the issues described in Section 8.1(1) must be filed as soon as the basis for the protest is known and after compliance with Section 8.2, but no later than 10 Days prior to the Proposal deadline. If the protest relates to an addendum to the RFP, the protest must be filed no later than five Business Days after the addendum is issued. Failure to bring any such protest within this time will be deemed a waiver and acceptance of the terms of the RFP and may not be realleged in any further protest.

Protests concerning the issues described in Section 8.1(2) must be filed no later than five Business Days after receipt of the Proposer's notification of non-responsiveness.

For protests concerning the issues described in Section 8.1(3), a Notice of Intent to Protest must be filed no later than five Business Days after the Notice of Proposed Award is posted, which shall be accompanied by a request for relevant procurement documents if the Proposer filing a protest needs additional documents to complete its protest. The Proposer filing a protest shall have five additional Business Days to file its protest following receipt of the relevant procurement documents from the Authority.

8.4 Content of Protest

Protests shall state, completely and succinctly, the grounds for protest, its legal authority, and its factual basis, and shall include all factual and legal documentation in sufficient detail to establish the merits of the protest.

Statements shall be sworn and submitted under penalty of perjury. Additionally, all protests shall contain the name, address, email address, and telephone numbers for the protestor, the RFP number of this procurement, a request for a ruling by the Protest Official, all information establishing that the protestor is a Proposer for the purposes of filing a protest, and all information establishing the timeliness of the protest. Protests must be filed by a named Proposer; a subcontractor member of a Proposer team may not independently file a protest.



8.5 Filing of Protest

Protests shall be filed by hand delivery on or before the applicable deadline to the Protest Official with a copy to the Authority's Designated Point of Contact identified in Section 3.1 as soon as the basis for the protest is known to the Proposer filing a protest. Additionally, a courtesy copy shall be delivered via email to the Authority's Designated Point of Contact. Copies of any protests received will be provided to all Proposers. The Protest Official for this RFP is:

Chris Rice
California High-Speed Rail Authority
770 L Street, Suite 620
Sacramento, CA 95814

8.6 Comments from Other Proposers

Other Proposers may file statements in support of, or in opposition to, the protest within seven Days of the filing of the protest. The Authority shall forward copies of all such statements to the Proposer filing a protest. Any factual determinations shall be sworn and submitted under penalty of perjury.

8.7 Authority Response to a Protest

The Authority's Designated Point of Contact or their designee may provide a response to the protest within three Business Days of the deadline for comments from other Proposers. The Authority's Designated Point of Contact or their designee shall have broad discretion to review all documents and information related to the protest and procurement when preparing this response. This written response shall be provided to the Protest Official and all Proposers, including the Proposer filing a protest.

8.8 Burden of Proof

The Proposer filing a protest shall have the burden of proof in proving its protest. The Authority may discuss, in its sole discretion, ask questions of an/or verify information of the protest with the Proposer filing a protest, other Proposers, the Authority's Designated Point of Contact for the procurement, and other members of the Authority's procurement team. No oral hearing will be held on the protest. The protest shall be decided on the basis of written submissions.

8.9 Decision on Protest

The Protest Official shall issue a written decision regarding the protest within 45 Days after the filing of the detailed statement of protest. The decision shall be final and conclusive and not subject to legal challenge unless wholly arbitrary. If



necessary to address the issues raised in a protest, in its sole discretion, the Authority may make appropriate revisions to this RFP by issuing addenda. Copies of decisions regarding protests and/or withdrawals of protests will be provided to all Proposers.

8.10 Limitation on the Authority’s Liability

The Authority shall not be liable for any damages to, or costs incurred by, any participant in a protest, on any basis, express or implied, whether or not successful.



Attachments

- Attachment A: Minimum Qualifications Checklist
- Attachment B: Criteria for Awarding Points for the Proposal
- Attachment C: Reference Materials
- Attachment D: Bid Tab Description

RFP No.: HSR25-89 TSCC ADDENDUM 8 04/01/2026



Attachment A: Minimum Qualifications Checklist

#	Minimum Qualification	Yes	No
1.	Was the Proposal received no later than the date and time listed in Table 1?		
2.	Did the Proposal include one original and five hard copies in separate 3-ring binders contained in a sealed shipping package? Is the Original marked “Original” on its face and spine, and each copy is marked with the Proposer’s name and numbered 1 through 5 on the spines?		
3.	Did the Proposer submit an electronic version of its Proposal to the Authority’s cloud folder? Is the electronic Proposal a single PDF file that is printable, searchable, and read-only? Can the PDF file be opened and printed without a password?		
4.	Is the Proposal typed? Are all documents that require signature manually or digitally signed by a person who is authorized to bind the Proposer or Proposer Team member, as applicable?		
5.	Does the Proposal meet the following page limitation requirements? <ul style="list-style-type: none"> a. Is the Executive Summary no more than 10 pages in length, inclusive of text, selected photographs, and sketches? b. Are the resumes (attached to the Transmittal Letter) only for Key Personnel and no more than 3 pages each? c. Is the Technical Proposal no more than 100 pages in length, exclusive of the Executive Summary, resumes for Key Personnel, schedules, forms, sketches, renderings, drawings, and plans? d. Is each plan limited to 25 pages? 		
6.	Is the Proposal tabbed and organized in the order set forth in the ITP at Section 6?		
	Volume 1A – ADMINISTRATIVE SUBMITTALS		
7.	Does the Proposal contain one original and five printed copies of Volume 1A?		
8.	Is each copy numbered 1 through 5 on its spine? Was a digital copy of Volume 1A provided?		
9.	Is Volume 1A organized with a tab for each Proposer Team member identified in Form C, with all requisite administrative submittals for that respective team member included in their tabbed section?		
10.	Form A: Did the Proposer submit the Transmittal Letter (Form A) with the following information? <ul style="list-style-type: none"> a. Transmittal Letter signed and completed by Official Representative. b. Letters of Commitment from Subcontractors (including all Key Subcontractors) attached. c. Surety letter (if applicable) as described in Section 6.4 of this ITP. d. Acknowledgment that Proposer’s questions were answered by the Authority. e. Resumes from Key Personnel limited to three pages each. f. Have all Key Personnel submitted a signed statement attached to the Transmittal Letter indicating that they understand the project office will be located in the Authority’s headquarters located at 770 L Street, Sacramento, CA 95814 or in the Central Valley area and are willing to work as required at 		

RFP No.: HSR25-89 TSCC ADDENDUM 8 04/01/2026



#	Minimum Qualification	Yes	No
	the location as determined by the work schedule, as required by ITP Section 6.4?		
11.	Form B: Identification of Proposer's RFP / Proposal Manager		
12.	Form C: Information about Proposer, Equity Members, Lead Designer, Lead Contractor, and Guarantors		
13.	Form D: Identification of Proposer Team Members		
14.	Form E: Key Personnel Matrix		
15.	Form F: Schedule of Subcontractor(s) – Is the form filled out and is evidence submitted with the Proposal that Subcontractors listed on Form F are registered with the Department of Industrial Relations.		
16.	Form G: Past Performance Certification		
17.	Form H: Organizational Conflicts of Interest Disclosure Statement		
18.	Form I: Verification, Validation, and Self-Certification Commitment		
19.	Form J: Proposal Price (Not in Vol. 1 – To be included only in Vol. 3 – Price Proposal)		
20.	Form K: Past Projects		
21.	Form L: Project Owner References		
22.	Form M: Key Personnel References – Each firm identified in a Key Personnel position shall have two references.		
23.	Form N: Disabled Veteran Business Enterprise Declaration – Including DGS PD 843 if Proposer intends to utilize Disabled Veteran Business.		
24.	Form S: Past Performance Questionnaire		
25.	Cert 1: Debarment, Suspension, Ineligibility, and Voluntary Exclusion Certification		
26.	Cert 2: Non-Collusion Affidavit		
27.	Cert 3: Organizational Conflicts of Interest Affidavit		
28.	Cert 4: Equal Employment Opportunity Certification		
29.	Cert 5: Non-Discrimination Certification		
30.	Cert 6: Certification Regarding Lobbying		
31.	Cert 7: Drug Free Workplace Program Certification		
32.	Cert 8: Buy America Compliance or Non-Compliance Certifications		
33.	Cert 9: Iran Contracting Certification		
34.	Cert 10: Darfur Contracting Act Certification		
35.	Cert 11: Certification Regarding Miscellaneous State Requirements		
36.	Cert 12: Proposer's Overall Project Small Business Goal Commitment Affidavit		
37.	Cert 13: California Civil Rights Laws Certification		
38.	Cert 14: DGS Forms - CCC 04/2017 and STD 204		
39.	Cert 15: Generative Artificial Intelligence Disclosure		
40.	Cert 16: Escrowed Proposal Documentation Certification		
41.	Surety Letter: The Proposal contains a letter from a California registered surety or insurance company, signed by an authorized representative, indicating that the Proposer is capable of fulfilling the bond requirement under this Contract as set forth in ITP Section 6.4.		
42.	Joint and Several Liability: If a joint venture, the Proposal contains a letter signed by each Equity Member accepting joint and several liability.		

RFP No.: HSR25-89 TSCC ADDENDUM 8 04/01/2026



#	Minimum Qualification	Yes	No
43.	Department of Industrial Relations Registration: The Proposal shall contain proof of DIR registration, for the Proposer and each Equity Member as well as each subcontractor listed on Form F.		
44.	Organizational Documents: The Proposal shall contain a copy of the articles of incorporation and bylaws, the joint venture agreement, partnership agreement, limited liability company agreement or equivalent organizational documents for the Proposer, each Equity Member, and any Guarantors.		
45.	Legal Issues, Liabilities or Proceedings: The Proposal shall include a statement explaining what legal issues, liabilities, or proceedings are presently before the Proposer and any Joint Ventures.		
46.	Environmental, Socioeconomic, and Governance Policies (ESG) - The Proposal shall include information and/or a report on its ESG efforts and policies per ITP Section 6.4.		
Volume 1B – FINANCIAL INFORMATION			
47.	Does the Proposal contain one original and five printed copies of Volume 1B?		
48.	Is each copy numbered 1 through 5 on its spine? Was a digital copy of Volume 1B provided?		
49.	Does Volume 1B contain a credit rating?		
50.	Does Volume 1B contain information pertaining to the Proposer's financial capacity criteria per ITP Section 6.5 (Profitability, Liquidity, Leverage, Performance, Other Financial Matters)?		
51.	Does Volume 1B contain recent Financial Statements per ITP Section 6.5(a) – (i)?		
52.	Guarantor Letter of Support - If the Proposer or any Equity Member includes a Guarantor as part of its submission, then the Proposal shall include a letter from each Guarantor stating that it will provide a performance guaranty in the form as set forth in Section 6.5 of the RFP.		
Volume 2 – EXECUTIVE SUMMARY and TECHNICAL PROPOSAL			
53.	Does the Proposal contain one original and five printed copies of Volume 2?		
54.	Is each copy numbered 1 through 5 on its spine? Was a digital copy of Volume 2 provided?		
EXECUTIVE SUMMARY			
55.	Does the Executive Summary contain a legal description of the Proposer's form of organization, identify the lead entity, the percentage of interest held by the Equity Members, and all entities that will have joint and several liability for the Contract or that will provide Guaranties?		
56.	Does the Executive Summary contain a summary of the Proposer's understanding and approach to the Work, including procurement, construction, and coordination with third parties?		
57.	Does the Executive Summary contain financial information regarding the Proposer's financial strength and capability to undertake and complete the Work?		
TECHNICAL PROPOSAL			
58.	Does the Technical Proposal include a description of the Proposer's understanding of the Work?		

RFP No.: HSR25-89 TSCC ADDENDUM 8 04/01/2026



#	Minimum Qualification	Yes	No
59.	Does the Technical Proposal identify at least one Key Personnel who is a California registered Professional Engineer?		
60.	Does the Technical Proposal include a schedule showing mobilization, construction of track and OCS work, design and construction of systems work, testing, and commissioning for the 119-mile First Construction Section?		
61.	References - Does the Proposer provide at least three clients as references as required by section 6.6.2 (a) of the ITP?		
62.	Reference Projects - Does the Proposer provide reference project(s) for each of their references as required by section 6.6.2 (b) of the ITP?		
63.	Understanding of the Contract and Delivery Approach – Does the Technical Proposal contain a description of the Proposer’s understanding of the contract and delivery approach as required by 6.6.2(c) of the ITP?		
64.	Proposer Team (6.6.2(d)) – Does the Technical Proposal contain a description of the Proposer team?		
65.	Key Personnel and Roles (6.6.2(e)) – Does the Technical Proposal include information regarding California professional or other licenses held by the Proposer’s Key Personnel?		
66.	Understanding of Project Elements and Requirements – Does the Technical Proposal contain a description of the Proposer’s understanding of the work requirements and approach to delivery as required by 6.6.2(f) of the ITP?		
67.	Traction Power, Train Control, and Communications Systems Approach (6.6.2(h)) – Does the Technical Proposal contain a description of the Proposer’s approach to delivery of the systems work?		
68.	Risk Management and Integration Approach (6.6.2(i)) – Does the Technical Proposal contain a description of the approach for risk management and integration?		
69.	O&M Phase Benefits (6.6.2(j)) – Does the Technical Proposal contain a narrative of the O&M phase benefits of Proposer’s approach?		
70.	Small Business (6.6.2 (k)) – Does the Technical Proposal include a general description of how it will meet the Authority’s Small Business Goals?		
71.	Small Business Performance Plan (6.6.2 (k)) – Does the Technical Proposal include a Small Business performance Plan?		
72.	Small Business Communication Plan (6.6.2 (l)) - Does the Technical Proposal include a Small Business Communication Plan?		
	Volume 3 – PRICE PROPOSAL		
73.	Does the Proposal contain one original volume labelled Price Proposal in a sealed envelope?		

RFP No.: HSR25-89 TSCC ADDENDUM 8 04/01/2026



Attachment B: Criteria for Awarding Points for the Proposal

Following or in conjunction with evaluation of each Proposal for responsiveness in Section 7 and for all minimum qualification items in Attachment A, the Authority will score each Proposal according to the criteria set forth below.

Each scored item as identified below will be evaluated as to how well it addresses the following criteria, as applicable:

- How well the Proposer demonstrates an understanding of all elements necessary to deliver the Project.
- How well the response demonstrates the Proposer’s ability to deliver the Project; and,
- How well the Proposer demonstrates an understanding of the risks and challenges related to the Project, and how well it demonstrates its ability to manage those risks and challenges.

	Technical Proposal Evaluation Criteria	Points
1.	<p>Understanding of Contract and Delivery Approach</p> <p>The extent to which the Proposal demonstrate a clear understanding of:</p> <ul style="list-style-type: none"> (a) the unique elements of the TSCC contract and delivery approach, including the contract structure and delivery approach; and (b) the core technical and project management skills required for successful delivery of the Project. 	5
2.	<p>Proposer Team, Organization, and Management Approach</p> <p>The extent to which the Proposer’s Organizational Chart and Management Approach demonstrates:</p> <ul style="list-style-type: none"> (a) Appropriate and sufficient resources to successfully deliver the Project (excluding the Systems OEM) within the Project Schedule; (b) An organizational and management structure (including the proposed Key Personnel) that will facilitate efficient and effective communication between the TSCC Contractor and the Authority and within the TSCC Contractor team; and (c) a well-defined, collaborative approach to project management and partnering for Proposer’s performance of the Work with an explanation of how it has been tailored to for the unique elements of the TSCC contract and delivery approach. 	5
3.	<p>Major Participants Past Experience</p> <p>The extent to which the Proposer’s Reference Projects demonstrate the strength of its technical skills, experience and other qualifications for the Project, especially experience with the follow types of projects and scope elements:</p> <ul style="list-style-type: none"> (a) High-speed rail projects; (b) Relevant rail systems, including train control (ETCS 2), OCS, Track (UIC60), telecommunications systems, and traction power; and 	25

RFP No.: HSR25-89 TSCC ADDENDUM 8 04/01/2026



	(c) Complex projects delivered through CMGC, CMAR, progressive design-build, or similar collaborative contracting delivery methods, especially those on which the Proposer served as the prime contractor.	
4.	<p>Key Personnel Past Experience</p> <p>The extent to which the Key Personnel Resumes demonstrate the strength of their respective technical skills, experience and other qualifications to perform their proposed roles on the Project, especially experience with similar roles on the following types of projects and scope elements:</p> <p>(a) High-speed rail projects;</p> <p>(b) Relevant rail systems, including train control (ETCS 2), OCS, Track (UIC60), telecommunications systems, and traction power; and</p> <p>(c) Complex projects delivered through CMGC, CMAR, progressive design-build, or similar collaborative contracting delivery methods, especially those on which the Proposer served as the prime contractor.</p>	20
5.	<p>Track and OCS Approach</p> <p>The extent to which the Proposer's Track and OCS Approach demonstrates a clear understanding of the work requirements, and a well-defined, comprehensive approach, for the following, and in each case, the extent to which the Proposer's proposed approach will facilitate successful Project delivery:</p> <p>(a) Laying track;</p> <p>(b) Completing the mobilization work described in NTP 1 as expeditiously as possible; and</p> <p>(c) Staging and scheduling work and managing workforces to ensure construction completion of CP1, CP2, CP3, and CP4 within the Project Schedule.</p>	15
6.	<p>Traction Power, Train Control, Telecommunication Systems and SCADA Systems Approach</p> <p>The extent to which the Proposer's Systems Approach demonstrates a clear understanding of the work requirements, and a well-defined, comprehensive approach, for the following, and in each case, the extent to which the Proposer's proposed approach will facilitate successful Project delivery:</p> <p>(a) Preparation of preliminary design for the systems;</p> <p>(b) The Proposer's procurement of an OEM, including timeline and deliverables and strategies for ensuring that the TSCC Contractor will get best value proposals from at least two (2) qualified proposers;</p> <p>(c) Design management and completion of systems design with the OEM;</p> <p>(d) Development of a price for the systems, including how Proposer will ensure that pricing involves a collaborative, transparent, open-book process that will lead to a reasonable and acceptable price for the Authority; and</p> <p>(e) Construction management and oversight of the OEM.</p>	15
7.	<p>Risk Management and Integration Approach</p> <p>The extent to which the Proposer's Risk Management and Integration Approach demonstrates a clear and deep understanding of and a well-defined,</p>	20



	<p>comprehensive approach for the following, and in each case, the extent to which the Proposer’s proposed approach will facilitate successful Project delivery:</p> <p>(a) The key risks, challenges, and opportunities related to the Project;</p> <p>(b) The risk mitigation, contingency pricing, and risk management approach for the Project;</p> <p>(c) The quality management process for Authority-provided materials and how Proposer will accept and integrate the materials into its work and manage any quality issues, when detected; and</p> <p>(d) Systems integration requirements among the track, OCS, and systems scopes of work.</p>	
8.	<p>O&M Phase Benefits</p> <p>The extent to which the Proposer’s Proposal demonstrates that its approach to systems design and construction of the entire Project, including any innovative strategies, will:</p> <p>(a) Minimize O&M and lifecycle costs; and Enhance rail operations.</p>	5
9.	<p>Small Business Participation</p> <p>The extent to which the Proposal demonstrates its approach to utilizing and engaging SB/MB/SB-PW/DVBE firms throughout the life of the project, including:</p> <p>(a) How the Proposer will meet the Authority’s SB goals and utilize SB firms throughout the life of the Project; and</p> <p>(b) How the Proposer will meet the Communications Plan requirements, including the approach and frequency of communications to SB firms regarding schedule, deadlines, status, and delays.</p>	5
10.	<p>Past Performance Questionnaire (Form S)</p> <p>The extent to which the Proposal demonstrates the Proposal Team’s past experience applicable to the project, including:</p> <p>(a) Ability to minimize claims, change orders, and/or disputes; and</p> <p>(b) Ability to meet schedule and cost targets for past projects.</p>	15
Maximum Technical Proposal Points		130



Attachment C: Reference Materials

Further information regarding Reference Materials is provided in Section 2.5 of this ITP. The Reference Materials are organized as follows:

- RM.1 Asset Definition and Data Dictionary Document (AD4)
- RM.2 Asset Information Standard, Ver. 3
- RM.3 BIM Manual, Rev 1
- RM.4 CADD Manual, Rev 4
- RM.5 Concept of Operations, March 2024
- RM.6 DOORS Manual, Rev 0
- RM.7 GIS Requirements Manual, Rev 3
- RM.8 Plans Preparation Manual, Rev 3
- RM.9 Quality Manual, Rev 1
- RM.10 Environmental Documents
 - RM.10.1 Central Valley Wye
 - RM.10.2 Fresno to Bakersfield
 - RM.10.3 Fresno to Bakersfield LGA
 - RM.10.4 Merced to Fresno
 - RM.10.5 Program-wide Documents
 - RM.10.6 Soundwalls
- RM.11 RESERVED
- RM.12 Engineering TSCC Reference Material – Summary of RM files
- RM.13 RAM Management Plan, Rev. 3
- RM.14 SDLC Requirements, Rev. 1
- RM.15 Governance Framework
- RM.16 CHSR – Design Criteria Manual (DCM) Rev. 7.0
- RM.17 CP1 Executed Design Criteria Manual Rev. 1.0
- RM.18 CP2-3 Executed Design Criteria Manual Rev. 2.0
- RM.19 CP4 Executed Design Criteria Manual Rev. 3.0
- RM.20 POLI-1045 Configuration Management Policy



RM.21	POLI-1080 Infrastructure Management Policy
RM.22	POLI-1114 Reliability Availability Maintainability Policy
RM.23	POLI-1145 Program Integration Policy
RM.24	POLI-1155 Requirements Management Policy
RM.25	GUIDE-0007 Asset Information Standard
RM.26	PLAN-1022_Interface_Management_Plan (IMP)
RM.27	PLAN-1025_System Engineering Management Plan (SEMP)
RM.28	PLAN-1026_Requirements Management Plan (RMP) (v0.1)
RM.29	PLAN-1029_Program Integration Management Plan
RM.30	PLAN-1032_Rail System Safety Plan
RM.31	PLAN-1033 RAM Management Plan
RM.32	PLAN-1034 Verification and Validation Management Plan (VVMP)
RM.33	PLAN-1037 System Certification and Acceptance Plan (SCAP)
RM.34	PLAN-1038 Project Configuration Management Plan (PCMP)
RM.35	CHSR System Development Life Cycle (SDLC) Rev. 2
RM.36	CHSRA MANUAL-0003 - BIM Manual V2
RM.37	CHSRA MANUAL-0004 - CADD MANUAL
RM.38	CHSRA MANUAL-0002 - Plans Preparation Manual
RM.39	Concept of Operations
RM.40	CHSRA MANUAL-0001 - GIS Requirements Manual
RM.41	GNRL-PWD-DC-MAN-00001 Document & Drawing Numbering Manual
RM.42	GUIDE-0005 Testing and Commissioning Strategy
RM.43	PD-ROD-SE-021 DOORS Manual
RM.44	PLAN-1004 Safety and Security Management Plan (SSMP)
RM.45	RPRT-0003 Preliminary Hazard Analysis (PHA)
RM.46	CP4-6.26.2-0001 Maintenance Concept Final
RM.47	CP4-6.26.3-0001 Maintenance Manual-Earthworks
RM.48	CP4-6.26.6-0001 Maintenance Manual-Drainage



RM.49	CP4-6.26.8-0001 Maintenance Manual-Structures
RM.50	CP4-6.26.9-0001 Maintenance Manual-Fences and Gates
RM.51	CHSR Enterprise and SoS Interface Register (v1.0)
RM.52	CHSR Scope Split Procurement Allocation (v2.0)
RM.53	Design Criteria Manual (v7.1)
RM.54	PLAN-1022 Interface Management Plan
RM.55	Cable Troughs Specifications (Draft)
RM.RSP1A	Ultimate Track Configurations Files (various)



Attachment D: Bid Tab Description

For the purposes of completing the Price Proposal and Form J, the Proposer shall assume the following dates:

- Package 2:
 - Package 2 NTP: July 22, 2026
 - Finish of Track Works: June 14, 2027
 - Finish of OCS Works: October 18, 2027
- Authority-Furnished Materials will be provided starting:
 - Ballast: September 1, 2026
 - Cross Ties: October 1, 2026
 - Rail: November 1, 2026
 - Catenary Pole: February 1, 2027
 - OCS Components: February 1, 2027
 - Cable Troughs: October 1, 2026
 - Cables: March 1, 2027

The following are descriptions of the work for Package 2 in Form J.

Geotextile Fabric

Contractor shall furnish, install and test in accordance with Contract documents Geotextile Fabric - Nonwoven geotextile fabric, manufactured in accordance with DCM 7.0 Section 27.2.3.5.3 and Caltrans SSP 88-1.02F. Fabric shall have a minimum grab tensile strength of 46 lb. and an apparent opening size (AOS) of ≤ 0.0083 inches (No. 70 sieve). UV stabilized, suitable for drainage and filtration beneath aggregate layers. Item includes all required excavation, labor, equipment, and related operations necessary to provide a complete and fully functional unit in place.

Inline Drain

Contractor shall furnish, install and test in accordance with Contract documents inline drains defined within specification 33 42 00, including all required excavation, labor, equipment, and related operations necessary to provide a complete and fully functional unit in place.

Perforated Underdrain Pipe



Contractor shall furnish, install and test in accordance with Contract documents 6-inch to 12-inch diameter perforated HDPE or PVC pipe designed for trackbed drainage systems. Pipe shall comply with ASTM F405 (HDPE), ASTM D2729 or ASTM D3034 (PVC), and DCM 7.0 Section 27.2.3.5.3. Slots or holes shall be uniformly distributed along the bottom of the pipe to allow infiltration and longitudinal flow. Installed at the invert of the trench with minimum 36 inches cover, unless otherwise justified. Item includes all required excavation, labor, equipment, and related operations necessary to provide a complete and fully functional unit in place.

Half circle perforated corrugated galvanized deck drain pipe 8" I.D.

Contractor shall furnish, install and test in accordance with the Contract documents Half-circle perforated corrugated drain pipe. The pipe is made of 0.079" galvanized steel, with perforations to allow water infiltration. Pipe shall meet ASTM F405 or equivalent standards.

Half circle perforated corrugated galvanized deck drain pipe 12" I.D.

Contractor shall furnish, install and test in accordance with the Contract documents Half-circle perforated corrugated drain pipe. The pipe is made of 0.079" galvanized steel, with perforations to allow water infiltration. Pipe shall meet ASTM F405 or equivalent standards.

Perforated Underdrain and Inline Drain Cleanout

Contractor shall furnish, install, and test PVC cleanout assemblies for underdrain and inline drain systems in accordance with the Contract Documents and DCM 7.0 Section 27.2.3.5.3.4. Each cleanout includes a tee junction, riser pipe, removable gasketed cap, and reinforced concrete collar. Pipe shall comply with ASTM D3034 SDR 35. Cleanout risers shall be a minimum of 3.28 ft in height, with access points provided at 300-ft intervals or at grade breaks and bends.

Wasco Bridge Deck Preparation

Contractor shall prepare deck surface of the Wasco Viaduct in accordance with specification 07 13 29 of the Contract documents, including removal of existing slab reinforcement.

Bridge Deck Waterproofing

Contractor shall furnish, install and test in accordance with the Contract documents Application of waterproofing on existing railway bridge decks. Work includes conditioning, primer application, and installation of a bituminous or synthetic membrane to block water penetration and safeguard the concrete structure. Contractor shall install the waterproofing prior to track or ballast placement.

Drainage Aggregate



Contractor shall furnish, install and test in accordance with the Contract documents Drainage backfill consisting of clean, angular crushed stone or gravel, graded per ASTM C33 No. 67 or Caltrans Section 68-1.025, with minimum void ratio of 30%. Used for bedding and envelope of underdrain systems as specified in DCM 7.0 Section 27.2.3.5.3. Filter material must extend to the top of subgrade or 6 inches below finished grade in unpaved areas.

Ballasted Track Work

Contractor shall install ballasted track in accordance with specification section 34 11 00. Bid item is inclusive of all material handling of Track Owner-Furnished Materials, Placing Bottom Ballast, Unloading and Placing Ties, Unloading and Installing Rails, Placing of Top Ballast, Track Measurement & Survey, Tamping, Stabilizing, Welding, Dressing to a Pre-Final elevation suitable for operating construction work trains to a max of 100mm superelevation and Dressing to the Final elevation after the use of construction work trains is completed.

This scope will include, tamping, stabilizing to the final elevation, destressing as required, and final track measurement.

Track Ballast

Contractor shall install and test in accordance with Contract documents Owner furnished Cubic feet of track ballast (from igneous rock) supplied in accordance with EN 13450, grading A, particle size 1 1/4 in. to 2 1/2 in., Class C2.

Concrete Ties

Contractor shall install and test in accordance with Contract documents Owner furnished Unit of mono-block pre-stressed concrete tie manufactured, tested and supplied according to EN13230, including fastenings and pads. Weight greater than 661 lb.

Concrete Ties With Under Sleeper Pads

Contractor shall install and test in accordance with Contract documents Owner furnished Ties under sleeper pads: Each prestressed monoblock concrete tie, approx. 8'-6" long × 12" wide × 10" high, with factory-applied 3/8" thick USP. Pad stiffness per EN 13146-9. Including pads.

Concrete Ties With Under Sleeper Pads and track Inner Guard Rails

Contractor shall install and test in accordance with Contract documents Owner furnished Ties under sleeper pads and track inner guard rail: Each prestressed monoblock concrete tie, approx. 8'-6" long × 12" wide × 10" high, with factory-applied 3/8" thick USP. Pad stiffness per EN 13146-9. Including pads.

Track Rail



Contractor shall install and test in accordance with Contract documents Owner furnished Track Rail - Feet of rail UIC 60E1 / EN 60 E1 according to EN 13674, inclined at 1:20.

Track Inner Guard Rails

Contractor shall install and test in accordance with Contract documents Owner furnished inner rail EN 60 E1 according to EN 13674-1.

Preparation of Subgrade

The Contractor shall survey, inspect and eventually prepare and test the prepared subgrade in accordance with the Contract Documents, especially specifications 31 05 00 'Common work results for earthworks' and 34 11 00 'Track Construction'.

This item includes excavation and all required labor, equipment, and related operations necessary to meet the prescribed thickness and finished grade tolerances for the subballast layer according to specification 34 11 26.16 'Subballast'.

Track Subballast

The Contractor shall install, test, and submit test results in accordance with the Contract Documents. Contractor-furnished subballast shall consist of an unbound, well-graded mixture with particle sizes from 0 to 1¼ inches, fully crushed, and having a combined resistance value (LA Abrasion + Micro-Deval) of less than 40.

The compacted subballast shall achieve a minimum bearing capacity of $Ev_2 \geq 17,400$ psi. Quantities shall be based on the dimensions shown on the Drawings for material placed and compacted in accordance with the Specifications.

Shoulder Fill (Sub-ballast)

Contractor shall install and test in accordance with Contract documents Owner furnished Shoulder Fill (Sub-ballast) composed of unbound mixtures well-graded 0 to 1¼", with combined resistance (LA + MDE) < 40 and fully crushed particles, used for drainage fills and shoulder areas. Minimum bearing capacity shall be $Ev_2 \geq 17,400$ psi. Volume is based on the dimensions shown on drawings for material compacted in accordance with the specifications.

Aluminum cable

Contractor shall furnish, install and test in accordance with the Contract documents Aluminum Cable defined within specification 34 30 49.

Steel pipe

Contractor shall furnish, install and test in accordance with the Contract documents Steel pipe defined within specification 34 30 49.

Aluminothermic Welding Kit



Contractor shall furnish, install and test in accordance with the Contract documents Aluminothermic Welding Kit defined within specification 34 30 49.**Cu-Al Bimetallic Connector**

Contractor shall furnish, install and test in accordance with the Contract documents Cu-Al Bimetallic Connector defined within specification 34 30 49.

Ending Bimetallic Lug Connector (Al-Cu)

Contractor shall furnish, install and test in accordance with the Contract documents Ending Bimetallic Lug Connector (Al-Cu) defined within specification 34 30 49.

OCS Foundation for single cantilever poles

Contractor shall furnish, install and test in accordance with the Contract documents OCS Foundation for Standard Pole (LINE ITEM 1 - FOUNDATION-STANDARD). This work includes but is not limited to preparing site, concrete, baseplate, Drilling caisson, rebar and rebar cages, grounding and bounding, anchor bolts and nuts. This work also covers all testing activities of these components. Contractor shall furnish, install and test any special nonstandard OCS items such as Bridge attachments, station fittings, special cantilevers or portals necessary for a complete installation. The quantity of individual concrete foundations built with the purpose of supporting item 50.040.025.

OCS Foundation for Counterweight & Line Item

Contractor shall furnish, install and test in accordance with the Contract documents OCS Foundation Standard - Counterweight - This work includes but is not limited to preparing site, concrete, baseplate, Drilling caisson, rebar and rebar cages, grounding and bounding, anchor bolts and nuts. This work also covers all testing activities of these components. The quantity of individual concrete foundations built with the purpose of supporting item 50.040.030.

OCS Foundation for Guy Anchor

Contractor shall furnish, install and test in accordance with the Contract documents OCS Foundation - Guy Anchor - This work includes but is not limited to preparing site, concrete, baseplate, Drilling caisson, rebar and rebar cages, grounding and bounding, bolts and nuts and the ancho base plate. This work also covers all testing activities of these components.

Pole - single cantilever (Authority-Furnished Materials)

Contractor shall install and test owner furnished poles for cantilever in accordance with the Contract documents. This work includes but is not limited to installing and testing owner furnished OCS poles which will hold one cantilever. (W10x8x33, length of 25.59 ft including the 24 inches by 24 inches by 2 inches base plate.)

Pole - Counterweight & Line Item (Authority-Furnished Materials)



Contractor shall install and test owner furnished poles for counterweight in accordance with the Contract documents. This work includes installing and testing owner furnished OCS poles which will hold a tensioning device and/or hold more than a single cantilever. (W 12x12x72, length of 28.22 ft including the 24 inches by 24 inches by 2 inches base plate.)

Downguy Assembly (DG-1) (Authority-Furnished Materials)

Contractor shall install and test owner furnished downguy assembly in accordance with the Contract documents. Downguy Assembly (DG-1) – This work includes but is not limited to installing and testing of downguy assemblies, connecting the higher portion of a pole to the guy anchor. This connection from the pole to the guy anchor can have one or two downguy assemblies depending on the loading requirements.

Counterweight Assembly (SCAT)

Contractor shall install and test owner furnished counterweight assembly in accordance with the Contract documents. Counterweight Assembly (SCAT) - The work includes but is not limited to installing and testing of counterweight assemblies including tensioning device, contact wire and/or messenger wire anchor and counterweight. There is one counterweight assembly unit for the contact wire and another one for the messenger wire.

Mid-Point Anchor Assembly

Contractor shall install and test owner furnished mid point anchor assembly in accordance with the Contract documents. All incidentals are owner furnished including cables, insulators and all small steel parts necessary for the assembly.

Cantilever (SCAT)

Contractor shall install and test owner furnished cantilever in accordance with the Contract documents. Cantilever (SCAT) – This work includes but not limited to installing and testing owner furnished individual cantilever assemblies, including insulators, tubes, small steel parts, fittings, boltings (owner furnished) necessary to install a cantilever on a supporting structure. All incidental are owner furnished including individual cantilever assemblies, including insulators, tubes, small steel parts, fittings, boltings necessary to install a cantilever on a supporting structure.

Negative Feeder Cable Support Assembly

Contractor shall install and test owner furnished negative feeder cable support assembly in accordance with the Contract documents. Cantilever (SCAT) Negative Feeder Cable Support Assembly – This work includes but is not limited to installing and testing of individual negative feeder cable support assemblies mounted on supporting structures including steel parts, insulators, fittings and boltings necessary.

Static Wire Bonding



Contractor shall furnish, install and test static wire bonding in accordance with the Contract documents. This work includes but is not limited to cable connections between the static wires and the rails.

Feeder Tap

Contractor shall install and test feeder tap in accordance with the Contract documents. This work includes but is not limited the cable connections between Traction Power sites and the OCS. Sub-stations and Switching stations each count 8 feeder taps; Paralleling stations count 4 feeder taps.

Only the connections between TP cables and the OCS on the gantries are included. Feeder taps located within TP facilities are not included in this item.

Section Insulator (SCAT)

This work includes but is not limited to installing and testing owner furnished Section Insulator.

Catenary System (Including messenger wire, contact wire, hangers & electrical connections)

Contractor shall install and test owner furnished Catenary System in accordance with the Contract documents.

Static Wire

Contractor shall install and test owner furnished Static Wire in accordance with the Contract documents.

Negative Feeder cable

Contractor shall install and test owner furnished negative feeder cable in accordance with the Contract documents.

Portal

Contractor shall install and test owner furnished Portal in accordance with the Contract documents. This work includes but is not limited to installing and testing the quantity of portals necessary to support the OCS or gantry in front of the traction power facility.

Single pole disconnect switch

Contractor shall install and test owner furnished single pole disconnect switch in accordance with the Contract documents.

Double pole disconnect switch

Contractor shall install and test owner furnished double pole disconnect switch in accordance with the Contract documents.



Emergency Exit

Contractor shall furnish, install and test emergency exits in accordance with the Contract documents. This work includes all associated emergency vehicle gates equipped with fire key box and emergency pedestrian gate. The unit includes excavation, concrete foundation and fence connections.

Locking System

Contractor shall furnish, install and test locking systems for each existing and new gate of the HSR access restricted right-of-way.

Post-mounted Sign

Contractor shall furnish, install and test in accordance with Contract documents Post-mounted Sign defined within specification 10 14 26.

Fence-mounted Sign

Contractor shall furnish, install and test in accordance with Contract documents Fence-mounted Sign defined within specification 10 14 26.

OCS-mounted Sign

Contractor shall furnish, install and test in accordance with Contract documents OCS-mounted Sign defined within specification 10 14 26.

OCS Pole-security and numbering plate

Contractor shall furnish, install and test in accordance with Contract documents OCS Pole security and numbering plate defined within IGTE 21474/014018, IGTE 21474/214104, IGTE 21474/214729 and IGTE 21474/214730.

Structure-mounted Sign

Contractor shall furnish, install and test in accordance with Contract documents Structure-mounted Sign defined within specification 10 14 26.

Cable Trough

Contractor shall install and test in accordance with the Contract documents Owner furnished cable trough. Minimum external dimensions: 13 $\frac{3}{4}$ in. width \times 7 $\frac{1}{8}$ in. height (including 2 in. thick cover). Item includes all required excavation, labor, equipment, and related operations necessary to provide a complete and fully functional unit in place.

Cable Trough - transitions to structures

Contractor shall furnish, install and test in accordance with the Contract documents transitions of the cable trough from main route on embankment to structures. The transition includes reinforced cast in situ concrete box of 3 feet wide and variable height up to 5 feet, including concrete reinforced lid with capacity to support 3 persons,



connection with cable containment of the structures, transition from standard cable trough to the transition unit, all operations and handling of the different parts to be constructed, including excavations and incidental fills with granular material if needed, formworks, steel, concrete and small material to build this unit.

Handrails

Contractor shall furnish, install and test in accordance with the Contract documents handrails and connection hardware at the embankment to structure transition locations. This item includes galvanized steel handrails complete, including posts, brackets, fittings, and fasteners. Handrails shall be fabricated from ASTM A500 or A53 steel tubing and hot-dip galvanized after fabrication per ASTM A123, with all connections welded or mechanically fastened as detailed in the plans. Installation shall include all labor, materials, anchorage, concrete footings (if required), and incidentals necessary to deliver a fully compliant, durable, and corrosion-resistant system.

Manholes

Contractor shall furnish, install and test manholes in accordance with the Contract documents. This work includes but is not limited to Manholes, 8'-0" × 8'-0" × 8'-0". Manholes shall be installed on each end of the under track ductbank. Item includes all required excavation, labor, equipment, and related operations necessary to provide a complete and fully functional unit in place.

Sound Barrier on MSE Wall

Contractor shall design, furnish, install and test Sound barrier on MSE wall in accordance with the Contract documents. This work includes but is not limited to designing, furnishing, installing and testing Sound Barrier which includes but is not limited to panels and connections. Item includes all required excavation, labor, equipment, and related operations necessary to provide a complete and fully functional unit in place. The foundation design for the sound barrier on the MSE wall will be provided by the Authority.

Sound Barrier on Structures and Guideway Foundations

Contractor shall design, furnish, install and test Sound Barriers on Structures, Embankment and Guideway Foundations in accordance with the Contract documents. This work includes but is not limited to designing, furnishing, installing and testing Sound Barrier which includes but is not limited to panels, foundations (if required) and connections. Item includes all required excavation, labor, equipment, and related operations necessary to provide a complete and fully functional unit in place.



General Conditions and Requirements

Contractor shall provide project-specific costs for general conditions and requirements, which include, but not limited to:

- Field Superintendence and Engineering
- Crew Site Sanitation
- Crew Water
- Crew Safety Gear
- Concrete Washouts
- Construction Survey
- 3rd Party Testing and Inspection
- As-Builts
- Craft Overtime
- On-Site Travel
- Training
- Estimating support
- Quality Control and Management
- Safety
- Scheduling
- Package material receiving, handling, and planning
- Package Risk Evaluation
- Permit, Licensing, Encroachment Support, and Fees related
- Environmental Obligation and Monitoring
- SWPP BMP Implementation and Site Maintenance
- Survey Control
- Preconstruction Site Survey
- Package Work Maintenance
- Mockups
- Mobilization, including but not limited to:
 - Site Offices
 - Physical plant mobilization
 - Temporary Utility, Water, Electricity, Sewer, etc.
 - Staging, Laydown, Warehousing
 - Temporary Access
 - Preparatory work that must be performed or costs incurred before starting work



Flagging Cost for TSCC Contractor

Contractor shall provide its anticipated flagging cost as part of Package 2 and in accordance with Section 20.4.7 of the TSCC Agreement. The flagging cost should not exceed \$1,000,000.

Owner Furnished Materials

The color-coded figure below is a depiction between owner furnished materials (OFM) and the contractor responsibility for OCS foundations and the vertical installation of the OFM components (foundation reinforcement, anchor bolts and leveling nuts are the responsibility of the contractor).

Delineation of OCS Owner Furnished Material

Gold = Contractor

Blue = Owner Furnished Material- Catenary Poles & • OCS Components

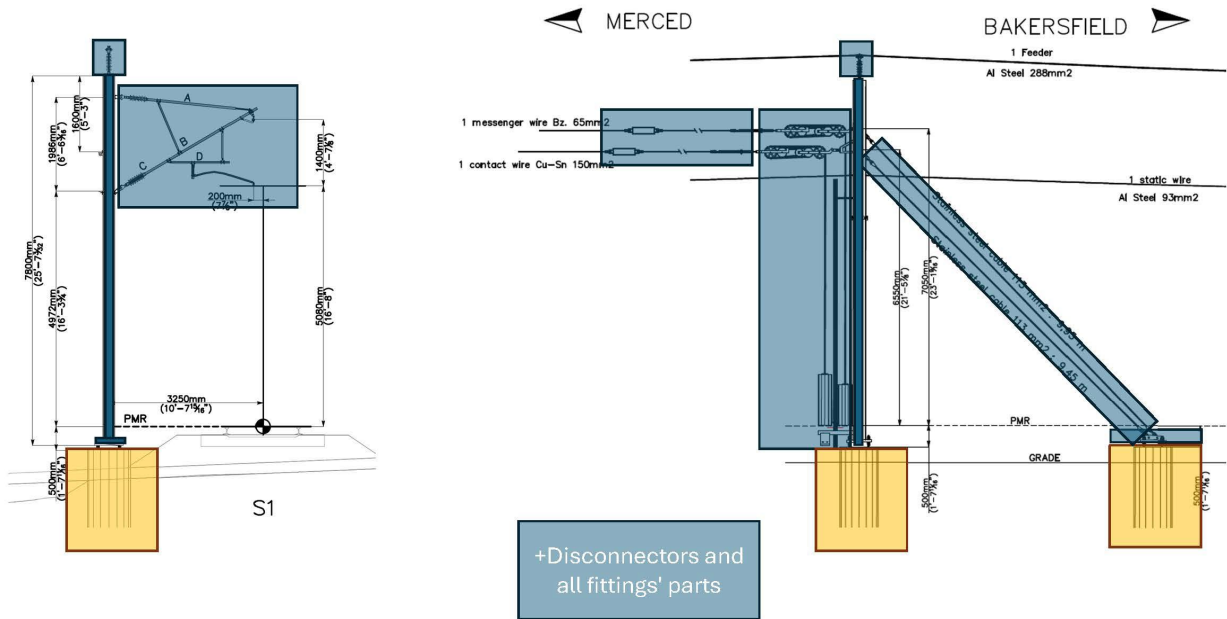

Typical Depiction for TSCC Base Project

RFP No.: HSR25-89 TSCC ADDENDUM 8 04/01/2026



Forms and Certifications

Forms

Form A:	Transmittal Letter
Form B:	Identification of Proposer’s RFP/Proposal Manager
Form C:	Information about Proposer, Equity Members, Lead Contractor, and Guarantors
Form D:	Identification of Proposer Team Members
Form E:	Key Personnel Matrix
Form F:	Schedule of Subcontractor(s)
Form G:	Past Performance Certification
Form H:	Organizational Conflicts of Interest Disclosure Statement
Form I:	Verification, Validation, and Self-Certification Commitment
Form J2:	Price Proposal Summary
Form K:	Past Projects
Form L:	Project Owner References
Form M:	Key Personnel References
Form N:	Disabled Veteran Business Enterprise Declaration
Form O:	Proposal Checklist
Form P:	Proposer Nondisclosure Agreement
Form Q:	Stipend Agreement
Form R:	Proposer Nondisclosure Agreement (Technical Drawings and Reports)
Form S:	Past Performance Questionnaire

Certifications

Cert. 1:	Debarment, Suspension, Ineligibility, and Voluntary Exclusion Certification
Cert. 2:	Non-Collusion Affidavit
Cert. 3:	Organizational Conflicts of Interest Affidavit
Cert. 4:	Equal Employment Opportunity Certification
Cert. 5:	Non-Discrimination Certification
Cert. 6:	Certification Regarding Lobbying



- Cert. 7: Drug Free Workplace Program Certification**
- Cert. 8: Buy America Compliance or Non-Compliance Certifications**
- Cert. 9: Iran Contracting Certification**
- Cert. 10: Darfur Contracting Act Certification**
- Cert. 11: Certification Regarding Miscellaneous State Requirements**
- Cert. 12: Proposer’s Project Small Business Goal Commitment Affidavit**
- Cert. 13: California Civil Rights Laws Certification**
- Cert. 14: CCC 04/2017 and STD 204**
- Cert. 15: Generative Artificial Intelligence Disclosure**
- Cert. 16: Escrowed Proposal Documents Certification**

RFP No.: HSR25-89 TSCC ADDENDUM 8 04/01/2026



Form A: Transmittal Letter**PROPOSER:** _____**Proposal Date:** _____

Emily Morrison
California High-Speed Rail Authority
770 L Street, Suite 620
Sacramento, CA 95814
eEmail: tsc@hsr.ca.gov

Dear Ms. Morrison

The undersigned Proposer submits this proposal in response to that certain Request for Proposals No. HSR25-89 dated as of November 26, 2025 (the RFP), issued by the California High-Speed Rail Authority (the Authority), as described in the RFP.

Enclosed, and incorporated herein and made a part of this proposal, are the documents listed in ITP Section 6.4.

Also attached are Letters of Commitment from our expected Subcontractors, pursuant to ITP Section 6.6.2(d).

Also attached are signed statements from each Key Personnel indicating that they understand the project office will be located in the Central Valley and are willing to work as required at the location as determined by the work schedule, as required by ITP Section 6.4.

Proposer represents and warrants that it has read the RFP and agrees to abide by the contents and terms of the RFP and Proposal.

Proposer certifies that this Proposal is submitted without reservation, qualification, assumptions or conditions. Proposer certifies that it has carefully examined and is fully familiar with all of the provisions of all of the RFP Documents, has reviewed all materials posted on the Project Website, the Addenda and the Authority's responses to questions and is satisfied that the RFP Documents provide sufficient detail regarding the obligations to be performed by the Contractor and do not contain internal inconsistencies; that it has carefully checked all the words, figures and statements in this Proposal; that it has conducted such other investigations and additional design development which are prudent and reasonable in preparing this Proposal; and that it has notified the Authority of any deficiencies in or omissions from any RFP Documents or other documents provided by the Authority.



Proposer represents that all statements made in its Proposal are true, correct and accurate as of the date hereof, except as otherwise specified.

Proposer authorizes the Authority to make any inquiries necessary to verify the information presented in this form and attachments, and to obtain any financial information necessary to evaluate Proposer Team’s capability to supply the necessary financial support to the Project.

Proposer understands that the Authority may reject each proposal the Authority may receive.

Proposer further understands that all costs and expenses incurred by it in preparing this Proposal and participating in the Project procurement process will be borne solely by the Proposer.

Proposer agrees that the Authority will not be responsible for any errors, omissions, inaccuracies, or incomplete statements in this Proposal.

This proposal shall be governed by and construed in all respects according to the laws of the State of California.

The undersigned affirms that the information provided herein is true and accurate and that any misrepresentations are made under penalty of perjury.

The Authority’s responses to the Proposer questions No. 1 through No. ## were posted on the California State Contracts Register.

Proposer’s business address:

No. Street Floor or Suite

City State or Province ZIP or Postal Code Country

State or Country of Incorporation/Formation/Organization: _____

Signature of Official Representative

Printed Name

Title



Note: The Transmittal Letter is to be executed by the Proposer's duly authorized Official Representative identified on Form D.

RFP No.: HSR25-89 TSCC ADDENDUM 8 04/01/2026



Form B: Identification of Proposer’s RFP/Proposal Manager

**CALIFORNIA HIGH-SPEED RAIL AUTHORITY
RFP No: HSR 25-89**

Name of Proposer:

Proposer’s RFP/Proposal Manager

Name:

Title:

Firm/Company:

Address:

Telephone No.:

Fax No.:

Email address:

Note: Any substitution of Proposer’s RFP Manager shall be made in writing to the Authority.

RFP No.: HSR25-89 TSCC ADDENDUM 8 04/01/2026



Form C: Information about Proposer, Equity Members, Lead Contractor, and Guarantors

Complete a separate Form C for the Proposer, each Equity Member, Lead Contractor, and any proposed Guarantor identified in Form D (Identification of Proposer Team Members). Please make additional copies of this form as needed.

Proposer Name: _____

Complete/Legal Name of Entity: _____

Entity Role (i.e., Proposer, Equity Member, Lead Engineering Firm, Lead Contractor, Guarantor): _____

Name of Official Representative: _____

Title of Official Representative: _____

California Contractor’s License(s) # (if applicable): _____

Standard Industry Classification Code: _____

Year Established: _____ Federal Tax ID No.: _____

Individual Contact: _____ Telephone No.: _____

Individual’s Title: _____ Fax No.: _____

Individual’s Email Address: _____

Business Organization (check one):

Corporation (If yes, then indicate the State and Year of Incorporation): _____

Partnership

Joint Venture

Limited Liability Company (If yes, then indicate the State and Year of formation): _____

Other (describe): _____

A. Business Name: _____

B. Business Address: _____

Headquarters: _____

Office Performing the Work: _____

Contact Telephone Number: _____

Number of employees _____ Year established _____

Yes No

Has your organization, or have you as a sole proprietor, ever filed bankruptcy or defaulted on any debts?

Is your organization, or are you as a sole proprietor, a party to any claim or lawsuit?

RFP No.: HSR25-89 TSCC ADDENDUM 8 04/01/2026



1. Small Business Status

Is your organization certified as a small business by the State of California, or have you applied for certification?

Yes No If yes, list your OSDS Number: _____

Date certified: _____

Application submitted to Office of Small Business Certification and Resources on: _____

Is your firm certified as a small business by any other governmental entity, or have you applied for certification?

Yes No

If yes, identify the governmental entity and list your identification number:

Date certified: _____

Application submitted to on: _____

2. Disabled Veteran Business Status

Is your firm certified as a DVBE, or have you applied for certification?

Yes No If yes, list your identification number: _____

Date certified _____

Application submitted to on: _____

3. Disadvantaged Business Enterprise

Is your firm certified as a DBE, or have you applied for certification?

Yes No

If yes, list your identification number(s): _____

Certifying Agency Name: _____

Date certified _____

Application submitted to on: _____

RFP No.: HSR25-89 TSCC ADDENDUM 8 04/01/2026



- 4. Is the firm under investigation by any agency of the Federal government (e.g., the Justice Department, SEC, Department of Defense, Federal Trade Commission, etc.) or by any agency of a State or foreign government?

Yes No

If yes, please explain:

RFP No.: HSR25-89 TSCC ADDENDUM 8 04/01/2026



5. Have any banks refused to lend to the firm in the last two (2) years?

Yes No

If yes, please explain:

Under penalty of perjury, I certify that the foregoing is true and correct, and that I am the Official Representative, as identified above, and am authorized to execute on behalf of the Proposer or entity for which this form is being completed:

Signature

Date

Printed Name

Title

Firm/Company Name

Proposer Name



NAME OF ENTITY	ROLE IN ORGANIZATION (Check all that apply)	NAME AND TITLE OF OFFICIAL REPRESENTATIVE
	<input type="checkbox"/> Equity Member <input type="checkbox"/> Guarantor <input type="checkbox"/> Lead Contractor <input type="checkbox"/> Subcontractor <input type="checkbox"/> Lead Designer	
	<input type="checkbox"/> Equity Member <input type="checkbox"/> Guarantor <input type="checkbox"/> Lead Contractor <input type="checkbox"/> Subcontractor <input type="checkbox"/> Lead Designer	
	<input type="checkbox"/> Equity Member <input type="checkbox"/> Guarantor <input type="checkbox"/> Lead Contractor <input type="checkbox"/> Subcontractor <input type="checkbox"/> Lead Designer	
	<input type="checkbox"/> Equity Member <input type="checkbox"/> Guarantor <input type="checkbox"/> Lead Contractor <input type="checkbox"/> Subcontractor <input type="checkbox"/> Lead Designer	

RFP No.: HSR25-89 TSCC ADDENDUM 8 04/01/2026

[THE REMAINDER OF THIS PAGE IS INTENTIONALLY BLANK.]



Form E: Key Personnel Matrix

Proposer: _____

Proposer hereby commits that, if awarded the contract, the Proposer will use the Key Personnel listed below for their stated positions and that, to the extent within the Proposer’s control, such individuals will be available on a full-time basis for the periods necessary to fulfill their Project-related responsibilities. The Proposer may recommend to the Authority that certain Key Personnel are not required to be available on a full-time basis throughout the Project in accordance with Section 6.4.

Please note that Individuals filling Additional Expertise roles must be readily available for short same-day notice, in-person meetings at the Authority’s headquarters located at 770 L Street, Sacramento, CA 95814 at the request of the Authority.

Authority’s Title	Proposer’s Title	Employing Firm	Proposed Individual	License/ Registration
Principal In Charge				
Construction Manager				
Engineering and Design Director				
Design Oversight Manager				
System Integration Manager				
Safety, Security and Certification Manager				
Track & OCS Installation Manager				
Traction Power System (TPS) Manager				
Communication Manager				
Train Control Manager				

RFP No.: HSR25-89 TSCC ADDENDUM 8 04/01/2026



Authority's Title	Proposer's Title	Employing Firm	Proposed Individual	License/ Registration
Civil/Structural Integration Manager				
Digital Manager				
Supply Chain Manager				

[SIGNATURE PAGE TO FOLLOW]

Signature of Official Representative

Printed Name

Title

[THE REMAINDER OF THIS PAGE IS INTENTIONALLY BLANK.]



Form F: Schedule of Subcontractor(s)

Names and Addresses of all Subcontractor(s)/Subcontractor(s)		Type of Work to be Performed and Percentage of NTP 1 and NTP 2 Proposal Price	Small Business Status (Check all that apply)		Previous Year's Annual Gross Receipts
Name:			<input type="checkbox"/> Yes <input type="checkbox"/> No		<input type="checkbox"/> < \$500K
Street Address:			Check all that apply	Certificate #	<input type="checkbox"/> \$500K-\$2 M
City, State Zip:					<input type="checkbox"/> \$2 Mil-\$5 M
Phone:			Age of Firm:	<input type="checkbox"/> DBE <input type="checkbox"/> SB <input type="checkbox"/> MB <input type="checkbox"/> DVBE	<input type="checkbox"/> > \$5M
Fax:					
Tax ID:					
Contact Person:					
Email:					
Name:			<input type="checkbox"/> Yes <input type="checkbox"/> No		<input type="checkbox"/> < \$500K
Street Address:			Check all that apply	Certification #	<input type="checkbox"/> \$500K-\$2 M
City, State Zip:					<input type="checkbox"/> \$2 M-\$5 M
Phone:			Age of Firm:	<input type="checkbox"/> DBE <input type="checkbox"/> SB <input type="checkbox"/> MB <input type="checkbox"/> DVBE	<input type="checkbox"/> > \$5M
Fax:					
Tax ID:					
Contact Person:					
Email:					
Name:			<input type="checkbox"/> Yes <input type="checkbox"/> No		<input type="checkbox"/> < \$500K
Street Address:			Check all that apply	Certification #	<input type="checkbox"/> \$500K-\$2 Mil
City, State Zip:					<input type="checkbox"/> \$2 M-\$5 M
Phone:			Age of Firm:	<input type="checkbox"/> DBE <input type="checkbox"/> SB <input type="checkbox"/> MB <input type="checkbox"/> DVBE	<input type="checkbox"/> > \$5M
Fax:					
Tax ID:					
Contact Person:					
Email:					

Add rows and pages as needed.

Attach to this form copy(s) of applicable Small Business Certificates for those Subcontractor that are designated as Small Business Entities.

[SIGNATURE PAGE TO FOLLOW.]



**Offering Organization Name,
Address, and Telephone**

Signature of Official Representative

Printed Name

Title

[THE REMAINDER OF THIS PAGE IS INTENTIONALLY BLANK.]

RFP No.: HSR25-89 TSCC ADDENDUM 8 04/01/2026



Form G: Past Performance Certification

Complete a separate Form G for the Proposer, each Equity Member, the Lead Contractor, and each Guarantor identified in Form D (Identification of Proposer Team Members). Please make additional copies of this form as needed.

Name of Firm: _____

- 1. Within the past ten years, has the firm or any affiliate¹ ever failed to complete any work it agreed to perform, or had a contract terminated?

Yes No

If yes, please explain, provide information concerning any such work completed by a surety, and provide owner contact information including telephone numbers:

¹ The term "affiliate" includes the firm's parent companies, its subsidiary companies, general partnerships, limited liability companies, joint venture members and/or business relationship in which the entity has more than a 15 percent financial interest.



- 2. Is any litigation pending by a project owner against the firm or any affiliate, including cross-claims?

Yes No

If yes, please explain and provide owner contact information including telephone numbers:

RFP No.: HSR25-89 TSCC ADDENDUM 8 04/01/2026



- 3. Has the firm, any affiliate, or any current officer thereof, been indicted or convicted of bid or other contract related crimes, or violations or any other felony or serious misdemeanor (i.e., fraud, bribery, collusion, conspiracy, antitrust, etc.) within the past five years?

Yes No

If yes, please explain:

RFP No.: HSR25-89 TSCC ADDENDUM 8 04/01/2026



4. Has the firm or any affiliate ever sought protection under any provision of any bankruptcy act?

Yes No

If yes, please explain:

RFP No.: HSR25-89 TSCC ADDENDUM 8 04/01/2026



- 5. Has the firm or any affiliate ever been debarred or suspended from performing work for the Federal government, any state or local government, or any foreign governmental entity, including ineligibility to bid or work on, or be awarded, a public works project pursuant to Section 1777.1 or 1777.7 of the California Labor Code?

Yes No

If yes, please explain:

RFP No.: HSR25-89 TSCC ADDENDUM 8 04/01/2026



- 6. Has the firm or any affiliate ever been assessed liquidated damages or stipulated damages during the past five years in excess of \$100,000 on any project (including penalties for nonconforming work as well as completion delay)?

Yes No

If yes, please explain including a description of any nonconforming work and a statement regarding the duration of the delay and the cause:

RFP No.: HSR25-89 TSCC ADDENDUM 8 04/01/2026



7. Is the firm currently asserting against any public agency any construction claim(s) in excess of \$100,000, or has it made any such claim(s) against any public agency during the past 2 years, or have any such claims been taken to arbitration or litigation during the past 10 years? For purposes of this question, the term “claim” shall include each separate demand for payment of money or damages arising from work done by or on behalf of the contractor in connection with a public works contract, which was disputed by the public agency, even though the agency may have ultimately agreed to make payment.

Yes No

If yes, please explain the circumstances surrounding the claims and /or litigation in detail:

RFP No.: HSR25-89 TSCC ADDENDUM 8 04/01/2026



8. Has the firm been awarded a design contract by a department, division, or other State of California agency within the past ten years?

Yes No

If yes, please identify the team members and the agencies, and provide agency contact information including telephone numbers.

RFP No.: HSR25-89 TSCC ADDENDUM 8 04/01/2026



9. Has the firm been awarded a construction contract by a department, division, or other State of California agency within the past ten years?

Yes No

If yes, please identify the team members and the agencies, and provide owner contact information including telephone numbers.

RFP No.: HSR25-89 TSCC ADDENDUM 8 04/01/2026



10. Has the firm ever been the subject of any inquiry by any public agency as to whether it has made any false claim or other material misrepresentation?

Yes No

If yes, as to each such inquiry, state the name of the public agency, the date of the inquiry, the grounds on which the public agency based the inquiry, and the result of the inquiry.

RFP No.: HSR25-89 TSCC ADDENDUM 8 04/01/2026



11. Has any construction project performed or managed by the firm been involved in repeated or multiple failures to comply with safety rules, regulations, or requirements? Has any serious or willful violation of Part 1 (commencing with Section 6300 of Division 5 of the Labor Code or the Federal Occupational Safety and Health Act of 1970 (Public Law 91-596), settled against the firm? If yes, describe.

Yes No

If yes, please identify the team members and the projects, provide an explanation of the circumstances, and provide owner contact information including telephone numbers.

RFP No.: HSR25-89 TSCC ADDENDUM 8 04/01/2026



12. Has any serious or willful violation of Part 1 (commencing with Section 6300 of Division 5 of the Labor Code or the Federal Occupational Safety and Health Act of 1970 (Public Law 91-596), settled against the firm?

Yes No

If yes, please identify the team members and the projects, provide an explanation of the circumstances, and provide owner contact information including telephone numbers.

RFP No.: HSR25-89 TSCC ADDENDUM 8 04/01/2026



13. Has the firm ever been fined for violating an environmental regulation?

Yes No

If yes, please identify the team members and the projects, provide an explanation of the circumstances, and provide owner contact information including telephone numbers.

RFP No.: HSR25-89 TSCC ADDENDUM 8 04/01/2026



14. Has the firm been convicted of violating a State or federal law respecting the employment of undocumented aliens in the past five years?

Yes No

If yes, please identify the team members and the projects, provide an explanation of the circumstances, and provide owner contact information including telephone numbers.

RFP No.: HSR25-89 TSCC ADDENDUM 8 04/01/2026



Authorization and Certification

I hereby authorize the California High-Speed Rail Authority to make any inquiries necessary to verify the information I have presented in this Form G and attachments and obtain any financial information necessary to evaluate my organization’s capability to supply the necessary financial support to the proposed project.

I hereby certify to the best of my knowledge and belief that I have read, understand, and do hereby accept the terms and conditions contained in this RFP.

Under penalty of perjury, I certify that the foregoing is true and correct, and that I am the Official Representative, as identified in Form B, and am authorized to execute on behalf of the Proposer or entity for which this form is being completed:

Signature

Date

Printed Name

Title

Firm/Company Name

Proposer Name

RFP No.: HSR25-89 TSCC ADDENDUM 8 04/01/2026



Form H: Organizational Conflicts of Interest Disclosure Statement**CALIFORNIA HIGH-SPEED RAIL AUTHORITY****A. Definition**

The Authority's Conflict of Interest Policy defines organizational conflicts of interest as follows:

Organizational Conflict of Interest means a circumstance arising out of a Contractor's existing or past activities, business or financial interests, familial relationships, contractual relationships, and/or organizational structure (i.e., parent entities, subsidiaries, Affiliates, etc.) that results in (i) impairment or potential impairment of a contractor's ability to render impartial assistance or advice to the Authority or of its objectivity in performing work for Authority, (ii) an unfair competitive advantage for any Proposer with respect to an Authority procurement; or (iii) a perception or appearance of impropriety with respect to any of the Authority's procurements or contracts or a perception or appearance of unfair competitive advantage with respect to a procurement by the Authority, regardless of whether any such perception is accurate.

[THE REMAINDER OF THIS PAGE IS INTENTIONALLY BLANK.]

RFP No.: HSR25-89 TSCC ADDENDUM 8 04/01/2026



B. Disclosure

In the space provided below, and on supplemental sheets as necessary, identify all relevant facts relating to past, present or planned interest(s) of the Proposer and its team, including Proposer, Proposer Team members, and all Subcontractors identified at the time of the submittal of its Proposal and their respective personnel, which may result, or could be viewed as, an organizational conflict of interest in connection with the RFP. If none exist, state “Not Applicable” in the spaces below.

RFP No.: HSR25-89 TSCC ADDENDUM 8 04/01/2026



3. Explanation

In the space below, and on supplemental sheets as necessary, identify steps that have been or will be taken to avoid or mitigate any organizational conflicts of interest described herein.

RFP No.: HSR25-89 TSCC ADDENDUM 8 04/01/2026



4. Certification

The undersigned hereby certifies that, to the best of his or her knowledge and belief, no interest exists that is required to be disclosed in this Organizational Conflicts of Interest Disclosure Statement, other than as disclosed above.

Signature of Official Representative

Printed Name

Title

**Offering Organization Name,
Address, and Telephone**

[THE REMAINDER OF THIS PAGE IS INTENTIONALLY BLANK.]

RFP No.: HSR25-89 TSCC ADDENDUM 8 04/01/2026



Form I: Verification, Validation, and Self-Certification Commitment

The undersigned hereby unequivocally commits to developing and implementing a verification and validation process in accordance with the California High-Speed Rail Authority’s Verification, Validation, and Self-Certification requirements, stated in Form I.

Signature of Official Representative

Printed Name

Title

[THE REMAINDER OF THIS PAGE IS INTENTIONALLY BLANK.]

RFP No.: HSR25-89 TSCC ADDENDUM 8 04/01/2026



Form J2: Price Proposal Summary

Proposer Name: _____ (the “Proposer”)

Date: _____

As of the date set forth above, pursuant to Section 6.7 of the ITP, the Proposer hereby offers its Price Proposal, which is comprised of this Form J2 (Price Proposal Summary) and Form J1 (Proposed Table of Rates and Prices) submitted herewith.

Packages	Proposed Price
Package 2	\$ [fill-in Package 2 Price from Proposed Table of Rates and Prices]

Fees	Proposed Percentages
TSCC Contractor Profit – self-performed Design Work	[fill-in from Proposed Table of Rates and Prices]%
TSCC Contractor Profit – subcontracted Design Work	[fill-in from Proposed Table of Rates and Prices]%
TSCC Contractor Profit - self-performed other Work	[fill-in from Proposed Table of Rates and Prices]%
TSCC Contractor Profit – subcontracted other Work	[fill-in from Proposed Table of Rates and Prices]%
TSCC Contractor Overhead	[fill-in from Proposed Table of Rates and Prices]%
TSCC Contractor Fee on Self-Performed Design Work	[fill-in from Proposed Table of Rates and Prices]%
TSCC Contractor Fee on Subcontracted Design Work	[fill-in from Proposed Table of Rates and Prices]%
TSCC Contractor Fee on Self-performed other Work	[fill-in from Proposed Table of Rates and Prices]%
TSCC Contractor Fee on Subcontracted other Work	[fill-in from Proposed Table of Rates and Prices]%

RFP No.: HSR25-89 TSCC ADDENDUM 8 04/01/2026



Signature of Official Representative

Printed Name

Title

RFP No.: HSR25-89 TSCC ADDENDUM 8 04/01/2026



Form K: Past Projects

Provide the following information for each of the reference projects identified in response to Section 6.6.2(b) of this ITP.

For projects in which more than one of the Proposer Team members were involved, Proposer may provide a single Form K. Please make additional copies of this Form as needed.

Name of Firm(s): _____

Project Name: _____

Project Location: _____

Date of Project Performance: _____

Project Owner: _____

Proposer's Contract Value _____

Project Construction Value
(at completion or projected at completion): _____

Project Delivery Method:

- CM At-Risk
- Design-Bid-Build
- Design-Build
- Design-Build-Maintain
- Bridging
- Public Private Partnership (P3 or PPP)
- Integrated Project Delivery
- Multiple Award Construction Contract
- Other: _____

Was this a federally funded Project? Yes No

Percentage of work or services performed on the above referenced project: _____

Project Owner Representative Contact Information:

Name: _____

Telephone Number: _____

Email Address: _____

Project Owner Additional Contact Information - 1

Name: _____

Telephone Number: _____

Email Address: _____

Project Owner Additional Contact Information - 2

Name: _____

Telephone Number: _____

Email Address: _____

RFP No.: HSR25-89 TSCC ADDENDUM 8 04/01/2026



Project Owner Additional Contact Information - 3

Name: _____

Telephone Number: _____

Email Address: _____

Brief Summary of Work or Services provided for the above referenced project:

RFP No.: HSR25-89 TSCC ADDENDUM 8 04/01/2026



Summary description of project schedule completion deadlines versus actual completion dates on the above referenced project:

[Empty response box for project schedule completion deadlines versus actual completion dates]

RFP No.: HSR25-89 TSCC ADDENDUM 8 04/01/2026



Describe overall requirements and performance as it pertains to budget, changes, claims, quality, safety, and environmental compliance (mitigation, monitoring, and reporting) and integration for the above referenced project:

RFP No.: HSR25-89 TSCC ADDENDUM 8 04/01/2026



Describe innovative solutions (if any) and approach to risk management used on the above referenced project:

RFP No.: HSR25-89 TSCC ADDENDUM 8 04/01/2026



Describe the integration and coordination (if any) between design, construction, and environmental compliance on the above referenced project:

RFP No.: HSR25-89 TSCC ADDENDUM 8 04/01/2026



I hereby authorize the California High-Speed Rail Authority to make any inquiries necessary to verify the information I have presented in this Form M and attachments. Under penalty of perjury, I certify that the foregoing is true and correct, and that I have been duly authorized to execute this certification on behalf of the following Proposer:

1. _____ 2. _____ 3. _____
4. Signature 5. 6. Date

7. _____
Printed Name

8. _____
Title

9. _____
Firm/Company Name

10. _____
Proposer Name

RFP No.: HSR25-89 TSCC ADDENDUM 8 04/01/2026



Form L: Project Owner References

Proposers shall have the project owner representative of each reference project for which Proposer submits a Form K complete this Form L.

The Authority is selecting TSCC Contractor for a new high-speed rail system in California. Major work elements of the Project include all required administrative, design, engineering, integration, permitting, coordination, manufacturing, supply, installation, construction, supervision, management, testing, verification, labor, materials, equipment, documentation, maintenance, and certification.

TO BE COMPLETED BY PROPOSER

Proposer Team: _____
Firm Name: _____
Project Name and Location: _____
Project Owner: _____

TO BE COMPLETED BY PROJECT OWNER

Owner’s Representative: _____
Contact Title: _____
Phone No.: _____
Email Address: _____
Dates of project performance: _____
Type of project: _____

RFP No.: HSR25-89 TSCC ADDENDUM 8 04/01/2026



Project description (including project dollar value and delivery method – i.e. design-build, public-private partnership, etc.):

RFP No.: HSR25-89 TSCC ADDENDUM 8 04/01/2026



Firm's Role on Project: _____

Percent of work actually performed by such entity: _____

Brief description of the Firm's performance on the above referenced project including your satisfaction with the schedule/timely delivery, quality, innovation and cost of the work as well as any claims or liquidated damages (use additional pages as necessary):

RFP No.: HSR25-89 TSCC ADDENDUM 8 04/01/2026



I verify that the above information is accurate and that I am the owner’s representative for the above referenced project:

Signature

Date

Printed Name

Title

Firm/Company Name

Proposer Name

RFP No.: HSR25-89 TSCC ADDENDUM 8 04/01/2026



Form M: Key Personnel References

Each individual identified as a Key Personnel position must have two references. Please make additional copies of this form as needed.

Summary of Key Personnel Team Member Information:

Proposer Team:

Name of Individual:

Project Role:

Years of Relevant Project Experience:

Key Personnel Project Reference Contact Information:

Project Name:

Project Owner:

Project Location:

Project Performance Dates:

to

Project Construction Value:

Project Reference Name:

Project Reference Title:

Project Reference Telephone:

Project Reference Email:

RFP No.: HSR25-89 TSCC ADDENDUM 8 04/01/2026



Brief description of the Key Personnel’s experience, competency, and performance on the above referenced project (use additional pages as necessary):

RFP No.: HSR25-89 TSCC ADDENDUM 8 04/01/2026



Form N: Disabled Veteran Business Enterprise Declaration

Please complete and submit the DGS PD 843, [Disabled Veteran Business Enterprise Declaration](http://www.documents.dgs.ca.gov/dgs/fmc/gp/pd/pd_843.pdf), for any DVBE participation at the Department of General Services website (www.documents.dgs.ca.gov/dgs/fmc/gp/pd/pd_843.pdf).

RFP No.: HSR25-89 TSCC ADDENDUM 8 04/01/2026



Form O: Proposal Checklist

This Proposal Checklist is provided to establish the organization of the Proposals. The information contained in the Proposal Checklist is not intended to substitute for or to supersede the requirements of the ITP. In the event of a conflict between the Proposal Checklist and the ITP, the ITP shall prevail. This is for Proposer’s use in preparing its Proposal and is not required to be submitted with the Proposal.

Proposal Format Requirements	
<input type="checkbox"/>	Each volume is contained in a separate three-ring binder.
<input type="checkbox"/>	Each volume is clearly indexed using pages with tabs and organized in the order set forth by the ITP, Section 6.3.

Required Document Title	Document Requirements
Volume 1A: Administrative Submittals	
<input type="checkbox"/>	1 Marked Original
<input type="checkbox"/>	5 Copies
<input type="checkbox"/>	1 digital copy submitted via Authority provided Box folder.
<input type="checkbox"/>	Transmittal Letter (Form A), including Letters of Commitment and signed statements from Key Personnel regarding co-location
	<p>“Original” is clearly marked on the face and spine of the three-ring binder.</p> <p>Sequentially numbered on the spine of each three-ring binder.</p> <p>Appropriately labeled as to clearly and concisely identify the contents which follow to the equivalent organizational standards and use a searchable format with appropriate bookmarks for all volumes except Volume 3.</p> <p>The Proposer shall complete the Transmittal Letter (Form A) and attach evidence of its authorized representative(s) to execute and deliver the Proposal and the Contract, Letters of Commitment from Subcontractors (including all identified Key Subcontractors) required by Section 6.6.2(d), and signed statements from Key Personnel required by Section 6.6.2(e).</p> <p>Additionally, all Key Personnel shall submit a signed statement indicating that they understand the project office will be located either at the Authority’s Sacramento headquarters located at 770 L Street, Sacramento, CA 95814, or in the</p>

RFP No.: HSR25-89 TSCC ADDENDUM 8 04/01/2026



	Required Document Title	Document Requirements
		Central Valley location, and are willing to work full time at that location as determined by the work schedule.
<input type="checkbox"/>	Identification of Proposer’s RFP / Proposal Manager (Form B).	Identifies the Proposal Manager
<input type="checkbox"/>	Information about Proposer, Equity Members, Lead Contractor, and Guarantors (Form C)	The Proposer, each Equity Member, Lead Contractor, and any proposed Guarantor identified on Form D.
<input type="checkbox"/>	Identification of Proposer Team Members (Form D)	Identifies the Proposal Team Members, their role on the Proposer Team, and the Official Representative for the purposes of executing any required forms or certifications included in the Proposal. All Subcontractors identified on Form B shall also be listed on Form D.
<input type="checkbox"/>	Key Personnel Matrix (Form E)	Form E confirms the availability of Key Personnel. This form shall be signed by the Proposer’s Official Representative.
<input type="checkbox"/>	Schedule of Subcontractor(s) (Form F)	Form F shall contain information regarding anticipated Subcontractors and be signed by the Proposer’s Official Representative. All Subcontractors listed on Form F must be registered with the Department of Industrial Relations pursuant to Labor Code section 1725.5 as applicable. Proof that Subcontractors listed on Form F are registered with the Department of Industrial Relations shall be provided in Volume 1A of the Proposal.
<input type="checkbox"/>	Past Performance Certification (Form G)	For the Proposer, each Equity Member, the Lead Contractor, and each Guarantor

RFP No.: HSR25-89 TSCC ADDENDUM 8 04/01/2026



	Required Document Title	Document Requirements
		identified in Form D (Identification of Proposer Team Members).
<input type="checkbox"/>	Organizational Conflicts of Interest Disclosure Statement (Form H)	One copy signed by the Proposer's Official Representative. Additionally, each Proposer Team member identified in Form D shall submit a copy signed by its respective Official Representative as identified in Form D.
<input type="checkbox"/>	Verification, Validation, and Self-Certification Commitment (Form I)	Signed by Proposer's Official Representative.
<input type="checkbox"/>	Proposed Table of Rates and Prices (Form J1)	To be submitted only with Volume 3 (Price Proposal) pursuant to Section 6.7.
<input type="checkbox"/>	Price Proposal Summary (Form J2)	To be submitted only with Volume 3 (Price Proposal) pursuant to Section 6.7.
<input type="checkbox"/>	Past Projects (Form K)	For each project identified in response to Section 6.6.2(b) of the Technical Proposal. At least one Form K submitted is for a project with a Project Construction Value over \$1 billion.
<input type="checkbox"/>	Project Owner References (Form L)	For each project for which the Proposer submitted a Form K.
<input type="checkbox"/>	Key Personnel References (Form M)	The Proposal contains a fully completed Form M, "Key Personnel References" for each reference for each firm identified in a Key Personnel position. Each firm identified in a Key Personnel position shall have two references.
<input type="checkbox"/>	Disabled Veteran Business Enterprise Declaration (Form N)	If Proposer intends to utilize one or more Disabled Veteran Business, the Proposal should contain a DGS PD 843, Disabled Veteran Business Enterprise Declaration.
<input type="checkbox"/>	Past Performance Questionnaire (Form S)	The Proposal contains a completed Form S signed by the respective Official Representative for the Proposer, each Equity Member, Lead Contractor, Lead Designer, and any Guarantor.
<input type="checkbox"/>	Debarment, Suspension, Ineligibility, and Voluntary Exclusion Certification (Cert. 1)	Signed by the Official Representative of the Proposer and each member of the Proposer Team identified in Form D.

RFP No.: HSR25-89 TSCC ADDENDUM 8 04/01/2026



	Required Document Title	Document Requirements
<input type="checkbox"/>	Non-Collusion Affidavit (Cert. 2)	Signed by the Proposer's Official Representative.
<input type="checkbox"/>	Organizational Conflicts of Interest Affidavit (Cert. 3)	The Proposer and each Proposer Team member identified in Form D shall submit a copy signed by its respective Official Representative also identified in Form D.
<input type="checkbox"/>	Equal Employment Opportunity Certification (Cert. 4)	The Proposer and each Proposer Team member identified in Form D shall submit a copy signed by its respective Official Representative also identified in Form D.
<input type="checkbox"/>	Non-Discrimination Certification (Cert. 5)	The Proposer and each Proposer Team member identified in Form D shall submit a copy signed by its respective Official Representative also identified in Form D.
<input type="checkbox"/>	Certification Regarding Lobbying (Cert. 6)	Each Equity Member identified in Form D shall submit a copy signed by its respective Official Representative also identified in Form D.
<input type="checkbox"/>	Drug Free Workplace Program Certification (Cert. 7)	The Proposer and each Proposer Team member identified in Form D shall submit a copy signed by its respective Official Representative also identified in Form D.
<input type="checkbox"/>	Buy America Compliance or Non-Compliance Certifications (Cert. 8)	The Proposer and each Proposer Team member identified in Form D shall submit a copy signed by its respective Official Representative also identified in Form D.
<input type="checkbox"/>	Iran Contracting Certification (Cert 9)	Each Equity Member identified in Form D shall submit a copy signed by its respective Official Representative also identified in Form D.
<input type="checkbox"/>	Darfur Contracting Act Certification (Cert. 10)	Each Equity Member identified in Form D shall submit a copy signed by its respective Official Representative also identified in Form D.
<input type="checkbox"/>	Certification Regarding Miscellaneous State Requirements (Cert. 11)	Each Equity Member identified in Form D shall submit a copy signed by its respective Official Representative also identified in Form D.
<input type="checkbox"/>	Proposer's Project Small Business Goal Commitment Affidavit (Cert. 12)	Signed by the Proposer's Official Representative.



Required Document Title		Document Requirements
<input type="checkbox"/>	California Civil Rights Law Certification (Cert. 13)	Signed by the Proposer’s Official Representative.
<input type="checkbox"/>	DGS Forms - CCC 04/2017 and STD 204 (Cert. 14)	The Proposal shall contain the Contractor Certification Clauses (CCC 04/207) and STD 204 forms. Both forms are available at the hyperlinks provided at Certification 14.
<input type="checkbox"/>	Generative Artificial Intelligence Disclosure (Cert. 15)	<p>Per Section 3.14, the Proposer must notify the State in writing if it: (1) intends to provide GenAI as a deliverable to the State; or (2), intends to utilize GenAI, including GenAI from third parties, to complete all or a portion of any deliverable that materially impacts: (i) functionality of a State system, (ii) risk to the State, or (iii) Contract performance</p> <p>Note - After evaluating responses, if the intended Proposer disclosed the use of GenAI, this information must be submitted to the Chief Information Officer (CIO). The CIO, ISO, and/or designees will conduct a risk assessment. The assessment may require the engagement of members of the program area with knowledge of the scope of the Contract, subject matter experts, stakeholders, and the Proposer. Once risk is determined, additional action may be required prior to award.</p>
<input type="checkbox"/>	Escrowed Proposal Documentation Certification (Cert. 16)	Proposer shall submit a completed Cert. 16 with the EPD submittal.
<input type="checkbox"/>	Surety Letter	Provide a letter from a surety or an insurance company indicating the Proposer’s capacity to obtain bonds consistent with the requirements of section 7 of the TSCC Agreement, subject to reasonable qualifications required by the surety. The surety or insurance company must be registered with the California State Insurance Commissioner, appear on the current

RFP No.: HSR25-89 TSCC ADDENDUM 8 04/01/2026



	Required Document Title	Document Requirements
		Authorized Insurance List in the State of California published by the Office of the Insurance Commissioner and an A.M. Best's Rating Service classification of A-XIV or better. Letters should include the Proposer's bonding capacity, with respect to the specified bonds in section 7 of the TSCC Agreement, for a single project and in aggregate.
<input type="checkbox"/>	Joint and Several Liability Letter (If Proposer is a Joint Venture)	Must be signed by each Equity Member indicating its acceptance of joint and several liability for the Proposer's obligations under its Proposal and resulting contract.
<input type="checkbox"/>	Department of Industrial Relations Registration	Proof of Department of Industrial Relations registration, as required by Section 6.4 of this ITP, for the Proposer and each Equity Member pursuant to Labor Code sections 1725.5 and 1771.1, as required by section 18.3 of the TSCC Agreement.
<input type="checkbox"/>	Organizational Documents	A copy of the articles of incorporation and bylaws, the joint venture agreement, partnership agreement, limited liability company agreement or equivalent organizational documents for the Proposer, each Equity Member, and Guarantors (if any), such documents shall be consistent with the responsibilities to be undertaken by such parties under the Contract.
<input type="checkbox"/>	Legal Issues, Liabilities or Proceedings	<p>The Proposal shall include the following information regarding legal issues, liabilities and proceedings:</p> <ul style="list-style-type: none"> a. Legal Issues: Identify and explain any significant anticipated legal issues which the Proposer must resolve in order to carry out the Project and its obligations under a Contract. b. Legal Liabilities: Provide a list and a brief description of all instances involving transportation civil infrastructure projects in which the

RFP No.: HSR25-89 TSCC ADDENDUM 8 04/01/2026



	Required Document Title	Document Requirements
		<p>Proposer or Equity Member (or its parent company; its subsidiary companies; any company under joint ownership with such firm; any joint ventures or limited liability companies in which such firm is a member; and any partnership in which such firm is a general partner) was (i) determined, pursuant to a final determination in a court of law, arbitration proceeding or other dispute resolution proceeding, to be liable for a material breach of contract or (ii) terminated for cause. For each instance, identify an owner’s representative with a current phone and fax number and, if available, e-mail address.</p> <p>c. Legal Proceedings: Provide a list and a brief description (including the resolution) of each arbitration, litigation, dispute review board, enforcement proceeding resulting in assessment of monetary penalty, fine or criminal penalty, and other dispute resolution proceeding involving Proposer or Equity Member (or its parent company; its subsidiary companies; any company under joint ownership with such firm; any joint ventures or limited liability companies in which such firm is a member; and any partnership in which such firm is a general partner) and involving an amount in excess of \$500,000 related to performance in transportation civil infrastructure projects or compliance with any environmental law with a contract value in excess of \$25 million.</p>
<input type="checkbox"/>	<p>Environmental, Socioeconomic, and Governance Policies (ESG)</p>	<p>The Proposer’s ESG efforts, which may include any environmental sustainability efforts, socio-economic equity policies, and governance policies, or a report that conforms to one of the following frameworks:</p>

RFP No.: HSR25-89 TSCC ADDENDUM 8 04/01/2026



	Required Document Title	Document Requirements
		a. ISO 2600-2010 Guidance on Social Responsibility; b. Global Reporting Initiative Sustainability Report; c. Organization for Economic Co-Operation and Development Guidelines for Multinational Enterprises; d. UN Global Compact: Communication of Progress; or e. .Other framework related to ESG; i.e.: Sustainability Accounting Standards Board, Task Force on Climate-Related Financial Disclosures, CDP, etc.
Volume 1B: Financial Information		
<input type="checkbox"/>	1 Marked Original	“Original” is clearly marked on the face and spine of the three-ring binder.
<input type="checkbox"/>	3 Copies	Sequentially numbered on the spine of each three-ring binder.
<input type="checkbox"/>	1 digital copy submitted via Authority provided Box folder.	Appropriately labeled as to clearly and concisely identify the contents which follow to the equivalent organizational standards and use a searchable format with appropriate bookmarks for all volumes except Volume 3.
<input type="checkbox"/>	Financial Information and Metrics	Proposal contains Financial Information including: credit rating (if applicable), profitability, liquidity, leverage, performance, and other material financial matters as described in ITP Section 6.5.
<input type="checkbox"/>	Recent Financial Statements	As set forth in ITP Section 6.5
Volume 2: Executive Summary and Technical Proposal		
<input type="checkbox"/>	1 Marked Original	“Original” is clearly marked on the face and spine of the three-ring binder.
<input type="checkbox"/>	5 Copies	Sequentially numbered on the spine of each three-ring binder.
<input type="checkbox"/>	1 digital copy submitted via Authority provided Box folder.	Appropriately labeled as to clearly and concisely identify the contents which follow to the equivalent organizational standards and use a searchable format



	Required Document Title	Document Requirements
		with appropriate bookmarks for all volumes except Volume 3.
<input type="checkbox"/>	Executive Summary	<p>The Executive Summary shall contain sufficient information to familiarize reviewers with the Proposer’s Project approach and its ability to satisfy the legal requirements of the Contract. The Proposer shall limit the Executive Summary to no more than 10 pages inclusive of text, selected photographs, and sketches. The Executive Summary page count is not counted toward the page limit requirement of the Technical Proposal. The Proposer shall highlight those items which, in the opinion of the Proposer, represent significant value to the Authority and which may distinguish its Proposal from those of others.</p> <p>At a minimum, the Executive Summary shall include the following:</p> <ol style="list-style-type: none"> a. Legal - A description of the Proposer’s form of organization, identifies the lead entity the percentage of interest held by the Equity Members, and all entities that will have joint and several liability for the Contract or that will provide Guaranties (if required) to the Authority. All entities identified in the Executive Summary must be identified initially by their full and correct legal names. b. Technical - A description of the Proposer’s understanding and approach to the Work, including design, construction and coordination with third parties. Include a summary of (i-) how the Proposer intends to achieve design and construction solutions that are efficient, schedule-sensitive, environmentally sound, durable, safe and maintainable; and (ii) the Project support concepts to be addressed in connection with the

RFP No.: HSR25-89 TSCC ADDENDUM 8 04/01/2026



	Required Document Title	Document Requirements
		<p>Work including support of public outreach, coordination with adjacent contracts and concepts for mobilization, delivery of materials and mitigation of traffic and other impacts during construction; and (iii) demonstration of relevant experience and lessons learned working in collaborative contract environments.</p> <p>c. Financial - Information regarding the Proposer’s financial strength and capability to undertake and complete the Work, including any other relevant information regarding the Proposer’s financial approach to completing the Work.</p>
<input type="checkbox"/>	<p>Technical Proposal</p>	<p>The Proposal shall include a Technical Proposal containing the information described in Section 6.6.2 of this ITP, Technical Proposal Evaluation Criteria, separated and labeled appropriately.</p> <p>The Technical Proposal shall be no more than 100 pages in length; excluding the Executive Summary, resumes for Key Personnel, schedules, sketches, renderings, drawings, and plans. Each plan is limited to 25 pages.</p> <p>The Technical Proposal shall be consistent with the requirements of the Contract.</p> <p>The Technical Proposal shall demonstrate that the Proposer has a clear understanding of the Work, and how the Work integrates into the overall Project requirements.</p>
	<p>Buy America Compliance Issues</p>	<p>The Technical Proposal shall include identification of any Buy America Compliance Issues</p>

RFP No.: HSR25-89 TSCC ADDENDUM 8 04/01/2026



Required Document Title	Document Requirements
References	The Technical Proposal contains at least three client references as described in Section 6.6.2(a) of this ITP.
Reference Projects	For each reference project identified along with the Proposer’s references, reference projects are included with the information required in Section 6.6.2(b) of this ITP.
Organization and Key Personnel	<p>Under the requirements of Section 6.6.2(d), the Technical Proposal includes an organizational chart with personnel for primary and support positions as well as a description of how the organization and management plan will evolve and how the Proposer intends to collaborate with the authority and Interfacing Contractors during design production.</p> <p>Proposers are advised to describe the composition of the Proposer team, and how activities are assigned. Proposers shall include a clear plan for mobilization, including the relocation of key personnel to Sacramento as well as the process for mobilizing relevant staff at the beginning of the Preconstruction and Construction portion to deliver the Work.</p> <p>The Proposer shall identify all known Subcontractors on Form F (Schedule of Subcontractors). For Work which will be accomplished by a Subcontractor(s), the Proposer shall include a letter of commitment from the proposed Subcontractor(s).</p> <p>The Proposer shall provide a time-phased staffing plan showing all positions needed to accomplish the various types of assignments for the duration of the Contract.</p>
Understanding of the Contract and Delivery Approach	The Proposer should include a discussion of the understanding of the Contract and delivery approach. (ITP Section 6.6.2(c))

RFP No.: HSR25-89 TSCC ADDENDUM 8 04/01/2026



Required Document Title	Document Requirements
Key Personnel and Roles	<p>All Key Personnel shall submit a signed statement indicating that they understand the project office will be located in Sacramento, California and are willing to work full time at that location as determined by the work schedule.</p> <p>The Technical Proposal shall contain a list of individuals who will fill the following key positions, per Section 6.6.2(d) and (e) of this ITP.</p> <p>Principal In Charge, Engineering Director, Design Oversight Manager, Interface Manager, Safety and Certification Manager, Installation Manager and Supply Chain Manager.</p>
Understanding of Project Elements and Requirements	<p>The Technical Proposal should include a discussion of the understanding of the Project elements, Project requirements, and how the Proposer team adds value and works toward the goal of achieving optimal efficiency for delivering the Work under the General Conditions to the Authority. (ITP Section 6.6.2(g))</p>
Traction Power, Train Control, and Communication Systems Approach	<p>The Technical Proposal shall include a narrative as set forth in ITP Section 6.6.2(h), that demonstrates the Proposer's approach to delivery of the Systems Work.</p>
Risk Management and Integration Approach	<p>The Technical Proposal shall include a narrative as set forth in ITP Section 6.6.2(i) demonstrating the Proposer's approach to risk management integration to facilitate successful delivery of the Project.</p>
O&M Phase Benefits	<p>The Technical Proposal shall include a narrative to demonstrate the O&M phase benefits of the Proposer's approach to the Work as set forth in ITP Section 6.6.2(j).</p>



Required Document Title		Document Requirements
	Small Business Commitment Description	As part of the Technical Proposal, the Proposer shall submit a general description of how it will meet the Authority’s Small Business Goals. (ITP Section 6.6.2(j))
	Small Business Performance Plan	The Proposer is expected to present a narrative (SB Performance Plan) detailing how it will utilize SB/MB/SB-PW/DBE/DVBEs throughout the life of the Contract. The Proposer shall identify firms being utilized to meet the SB Program goals, including the estimated contract values and scopes of work that will be used to meet these goals. (ITP Section 6.6.2(j))
	Small Business Communication Plan	The SB Performance Plan shall contain a separately titled section that includes a description of how the Proposer intends to meet the requirements of the Communication Plan as described in Section 3.16 of the ITP. The Communication Plan shall relay the Proposer’s commitment to monthly reports to the Authority that document communication to SB/DB/DVBE subcontractors regarding schedule, deadlines, status, and delays. (ITP Section 6.6.2(k)).
Volume 3: Price Proposal		
<input type="checkbox"/>	1 Marked Original	“Original” is clearly marked on the face and spine of the three-ring binder.
<input type="checkbox"/>	2 digital copies submitted via separate USB drives.	Appropriately labeled as to clearly and concisely identify the contents which follow to the equivalent organizational standards and use a searchable format.

RFP No.: HSR25-89 TSCC ADDENDUM 8 04/01/2026



Required Document Title		Document Requirements
<input type="checkbox"/>	Proposed Table of Rates and Prices	The Proposal contains a fully completed Form J1 described in Section 6.7 of this ITP.
<input type="checkbox"/>	Price Proposal Summary	The Proposal contains a fully completed Form J2 described in Section 6.7 of this ITP.



Form P: Proposer Nondisclosure Agreement

**California High-Speed Rail Authority
Track and Systems Construction Contract (TSCC)
Nondisclosure Agreement**

I, _____, hereby agree as follows:

I will maintain the strict confidentiality and will not disclose information related to the design and details of the S220 catenary system, developed by SNCF RESEAU and being used under license by the California High Speed Rail Authority (Authority), beyond the needs for developing a proposal for the **TSCC, RFP No.: HSR25-89**.

I further acknowledge that this information accessible through BOX is deemed Confidential Information and is the exclusive property of the Authority and to be used within the strict scope and needs of the TSCC.

As a result, the I will not use the Confidential Information for research purposes, will not apply for or register any industrial or intellectual property rights in direct or indirect relation to the Confidential Information, nor claim any copyright or other intellectual property rights associated with the design and details of the S220 catenary system.

I hereby execute this Confidentiality Agreement and acknowledge that I may be subject to criminal, civil and/or financial penalties for breaching this Confidentiality Agreement.

Signature

Date

Printed Name

Printed Title

Representing

RFP No.: HSR25-89 TSCC ADDENDUM 8 04/01/2026



Form Q: Stipend Agreement

SCO ID: 2665-HSR26XX

STATE OF CALIFORNIA - DEPARTMENT OF GENERAL SERVICES
STANDARD AGREEMENT
 STD 213 (Rev. 04/2020)

AGREEMENT NUMBER HSR26-XX	PURCHASING AUTHORITY NUMBER (If Applicable) 2665
-------------------------------------	--

1. This Agreement is entered into between the Contracting Agency and the Contractor named below:

CONTRACTING AGENCY NAME
 California High-Speed Rail Authority

CONTRACTOR NAME
 Proposer (defined in the Instructions to Proposers – RFP No.: HSR25-89)

2. The term of this Agreement is:

START DATE
 TBD and in alignment with the Instructions to Proposers – RFP No.: HSR25-89

THROUGH END DATE
 TBD and in alignment with the Instructions to Proposers – RFP No.: HSR25-89

3. The maximum amount of this Agreement is:
 \$1,000,000.00 (One million dollars and zero cents)

4. The parties agree to comply with the terms and conditions of the following exhibits, which are by this reference made a part of the Agreement.

Exhibits	Title	Pages
Exhibit A	Stipend Agreement Scope of Work	2-3
Exhibit B	Stipend Agreement Budget Detail and Payment Provisions	4-6
Exhibit C	Stipend Agreement General Terms and Conditions	7-8

Items shown with an asterisk (), are hereby incorporated by reference and made part of this agreement as if attached hereto.
 These documents can be viewed at <https://www.dgs.ca.gov/OLS/Resources>*

IN WITNESS WHEREOF, THIS AGREEMENT HAS BEEN EXECUTED BY THE PARTIES HERETO.

CONTRACTOR

CONTRACTOR NAME (if other than an individual, state whether a corporation, partnership, etc.)

CONTRACTOR BUSINESS ADDRESS	CITY	STATE	ZIP
-----------------------------	------	-------	-----

PRINTED NAME OF PERSON SIGNING	TITLE
--------------------------------	-------

CONTRACTOR AUTHORIZED SIGNATURE	DATE SIGNED
---------------------------------	-------------

STATE OF CALIFORNIA

CONTRACTING AGENCY NAME
 California High Speed Rail Authority

CONTRACTING AGENCY ADDRESS 770 L Street, Suite 620	CITY Sacramento	STATE CA	ZIP 95814
---	--------------------	-------------	--------------

PRINTED NAME OF PERSON SIGNING	TITLE
--------------------------------	-------

CONTRACTING AGENCY AUTHORIZED SIGNATURE	DATE SIGNED
---	-------------

CALIFORNIA DEPARTMENT OF GENERAL SERVICES APPROVAL	EXEMPTION (If Applicable)
--	---------------------------

Stipend Agreement (8 pages total)



EXHIBIT A: SCOPE OF SERVICES

A. BACKGROUND, GOALS AND PURPOSE

1. The Stipend Agreement Contractor is also the same party defined as a Proposer and is participating in a competition with other proposers for the design and construction services of the TSCC Project, as described in the Instructions to Proposers – RFP No.: HSR25-89.
2. Information regarding the technical and design requirements of the Project is contained in the RFP.
3. The Authority agrees to pay Contractor an amount not to exceed \$1,000,000.00 as specified herein upon the completion of all tasks described to the satisfaction of the Authority and a responsive Proposal provided by the Proposal Deadline set forth in RFP.
4. The Authority reserves the right to reject any and all Proposals and makes no guarantee that it will award a Contract for the Project.
5. The Authority reserves the right to re-advertise the RFP.
6. Contractor is advised that execution of this Agreement by the Authority does not constitute a commitment to undertake the Project or enter into Contract for all or any portion of the Project.
7. Compensation to any subcontractor will be the responsibility of the Contractor.

B. SERVICES

1. Contractor agrees to prepare and submit a responsive Proposal for the Project by the due date specified in the ITP, in conformance with the terms of the RFP and with the requirements, terms, conditions, rules, and regulations of the solicitation process, identified in the RFP.
2. The documents included in the RFP and designated as the Contract Documents are provided by the Authority to establish the scope, level of quality and design intent for the development, design and construction of the entire Project. The Contractor shall not provide any exceptions to the RFP.
3. Contractor shall furnish all material, labor, tools, equipment, apparatus, and facilities necessary to perform and complete in a workmanlike manner the services called for in this Agreement. Contractor warrants that all design and engineering services under this Agreement will be performed by firms and/or individuals holding appropriate professional licenses with the State of California (State).
4. Contractor agrees to execute and deliver the Proposal in the form provided by the Authority, as well as other documents required of the ITP, without negotiations.



5. Contractor shall not have any contact or discussion with any appointed official, employee or staff member of the Authority California Department of Transportation, California Department of General Services, Federal Railroad Administration, or any of the firms identified in Table 3 of the ITP as being subject to Proposer ex parte communications regarding any element of the proposal solicitation process or the Project except as specifically permitted by the RFP. Failure of Contractor to comply with this requirement shall constitute a material breach of this agreement, thereby relieving the Authority of any and all obligations for payment to Contractor and may result in Contractor's dismissal from further participation in the solicitation process as provided in ITP. Such dismissal shall not constitute termination for which Contractor may be entitled to payment.

C. SCHEDULE OF SERVICES

1. All services shall be completed by the Proposal Deadline specified in the ITP unless an amendment to this agreement is executed which modifies the term of this Agreement and aligns with any addendum to the RFP.
2. This Agreement shall become effective upon the date of final approval by the Authority and shall continue until satisfactory completion of all services described herein unless otherwise terminated as herein provided.

D. AUTHORITY REPRESENTATIVE

1. For the purpose of the Stipend Agreement, Authority's representative authorized to direct services shall be the individual designated as the Authority's Point of Contact is:

Bruce Roberts
Contract Office
770 L Street, Suite 620
Sacramento, CA 95614
Phone: (916) 330-5633
Email: TSCC@hsr.ca.gov

2. The Authority representative is not authorized by the Authority to make any commitments or changes that will affect the price, terms or conditions of this Agreement absent an amendment.



EXHIBIT B: BUDGET DETAIL AND PAYMENT PROVISIONS

1 BUDGET CONTINGENCY CLAUSE

1.1 It is mutually agreed that this Agreement shall be of no further force and effect if the Budget Act of the current year and/or any subsequent years covered under this Agreement does not appropriate sufficient funds for work identified in Attachment A. In this event, the Authority shall have no liability to pay any funds whatsoever to the successful Contractor or to furnish any other considerations under this Agreement and the Contractor shall not be obligated to perform any provision of this Agreement.

1.2 After execution or commencement of this Agreement, if the funding for any fiscal year is reduced or deleted by the Budget Act for purposes of this project, the Authority shall have the option to either: 1) cancel this Agreement with no further liability occurring to the Authority; or 2) offer an Agreement amendment to the Contractor to reflect the reduced amount.

1.3 This Agreement is valid and enforceable only if sufficient funds are made available to the State by the United States Government or the California State Legislature for the purpose of this program. In addition, this Agreement is subject to any additional restrictions, limitations, conditions, or any statute enacted by the Congress or State Legislature that may affect the provisions, terms or funding of this Agreement in any manner.

2 INVOICING AND PAYMENT

2.1 For services satisfactorily rendered in accordance with the terms of this Agreement, and upon receipt and approval of the invoices by the Authority Contract Manager, the Authority agrees to compensate the Contractor with a lump sum payment upon completion and delivery of services required to provide a responsive Proposal.

A. Payment is conditioned upon Contractor's full conformance with all of the requirements of the services described in the RFP, including the timely delivery of the Proposal, including all drawings and other materials specified in the RFP, and no payment will be due if Contractor fails to meet any such requirement.

2.2 No payment shall be made in advance of services rendered.

2.3 The following certification shall be included on each invoice and signed by the authorized official of the Contractor. "I certify that this invoice is correct and proper for payment and reimbursement for these costs has not and will not be received from any other sources, including but not limited to a government entity contract, subcontract, or other procurement method.

2.4 The total amount payable by the Authority for this Agreement shall not exceed \$1,000,000.

2.5 The Contractor shall not submit an invoice until one business day after the earlier to occur of (i) receipt of notification that the Authority has entered into a Contract with



another proposer (ii) receipt of notification that the Authority will not award a Contract, or (iii) expiration of the time period for award stated in the RFP, as the same may have been extended by the Authority pursuant to the terms of the RFP without award having been made.

Provide the Invoice for Payment to:

Financial Office
California High-Speed Rail Authority
770 L Street, Suite 620 MS 3
Sacramento, CA 95814
accountspayable@hsr.ca.gov
(electronic signatures are acceptable)

AND

The Contractor shall also submit one additional electronic copy of the invoice and supporting documentation to the Authority Contract Manager or designee at the email address identified herein.

The Contractor may not submit an invoice if it has been advised by the Authority that its Proposal is non-responsive or otherwise failed to comply with any requirement of this Agreement.

2.9. Upon payment of said sum to Contractor, dismissal of Contractor from further participation in the solicitation process as provided in the RFP, or upon delivery of the fully executed Contract to Contractor if it is selected for award, Authority will have no further financial obligation to Contractor under this Agreement, and Contractor agrees not to make or pursue any claim for additional compensation through any remedy or for any reason.

3 PAYMENT REQUEST FORMAT

3.1 The Authority will accept computer generated or electronically transmitted invoices. The date of invoice receipt shall be the date the Authority receives the paper copy.

3.2 A request for payment shall reference the Agreement number and shall consist of, but not be limited to, the following:

3.2.1 Agreement number, date prepared, and billing period.

3.2.2 Documentation of Contractor's services and expenses, direct or indirect, including costs incidental to providing the services not to exceed \$1,000,000.00.



4 COST PRINCIPLES

4.1 The Contractor agrees to comply with procedures in accordance with 48 C.F.R., Federal Acquisition Regulations System, Chapter 1, Part 31, et seq., to determine the allowability of individual items of cost.

4.2 The Contractor agrees to comply with 49 C.F.R. Part 19, Uniform Administrative Requirements for Grants and Cooperative Agreements with Institutions of Higher Education, Hospitals and Other Non-Profit Organizations.

4.3 Any costs for which payment has been made to the Contractor that are determined by subsequent audit to be unallowable under 48 C.F.R. Part 31, as amended, or 49 C.F.R. Part 19, are subject to repayment by the Contractor to the Authority.

4.4 Any sub agreement in excess of \$25,000 entered into as a result of this Agreement shall contain all the provisions of this clause.

5 PROMPT PAYMENT ACT

5.1 Payment will be made in accordance with, and within the time specified in, Government Code Chapter 4.5, commencing with section 927.

6 EXCISE TAX

6.1 The State of California is exempt from federal excise taxes, and no payment will be made for any federal excise taxes levied on the Contractor. The Authority will only pay for any state or local sales or use taxes on the services rendered to the Authority pursuant to this Agreement. For clarification on excise tax exemptions, refer to the State Administrative Manual section 3585.

7 INVOICE DISPUTES

7.1 Payments shall be made to the Contractor for undisputed invoices. An undisputed invoice is an invoice submitted by the Contractor for services rendered and for which additional evidence is not required to determine its validity. The invoice will be disputed if all deliverables due for the billing period have not been received and approved, if the invoice is inaccurate, or if it does not comply with the terms of the Agreement. If the invoice is disputed, the Contractor will be notified via a Dispute Notification Form, or with other written notification within 15 working days of receipt of the invoice. The Contractor will be paid the undisputed portion of the invoice.



EXHIBIT C: GENERAL TERMS AND CONDITIONS

GTC 610

Under the California High-Speed Rail Authority's standardized agreement process, a hardcopy of Exhibit C, GTC 610, is not included in the standard agreement package. As indicated on the Std. 213, a copy of Exhibit C can be found at the internet site:

<https://www.dgs.ca.gov/OLS/Resources>

If you do not have internet access, please contact the Authority Representative below to receive a copy:

Bruce Roberts
Contract Office
770 L Street, Suite 620
Sacramento, CA 95614
Phone: (916) 330-5633
Email: TSCC@hsr.ca.gov

EXHIBIT D: SPECIAL TERMS AND CONDITIONS

1 CONTRACT MANAGEMENT

1.1 The Contractor's Project Manager is responsible for the day-to-day project status, decisions and communications with the Authority's Contract Manager. The Contractor may change its Project Manager by giving written notice to the Authority, but the Authority reserves the right to approve any substitution of the Project Manager. This approval shall not be unreasonably withheld.

1.2 The Authority may change its Contract Manager at any time by giving written notice to the Contractor.

2 SUBCONTRACTS

2.1 Nothing contained in this Agreement or otherwise, shall create any contractual relation between the Authority and any subcontractors, and no subcontract shall relieve the Contractor of his or her responsibilities and obligations under this Agreement. The Contractor agrees to be as fully responsible to the Authority for the acts and omissions of its subcontractors and of persons either directly or indirectly employed by any of them as it is for the acts and omissions of its subcontractors and of persons either directly or indirectly employed by the Contractor. The Contractor's obligation to pay its subcontractor is an independent obligation from the Authority's obligation to make payment to the Contractor. As a result, the Authority shall have no obligation to pay or enforce the payment of any moneys to any subcontract.



2.2 The Contractor shall perform the work contemplated with resources available within its own organization and no portion of the work shall be contracted without written authorization by the Authority's Contract Manager, except that which is expressly identified in the Budget Detail.

2.3 Unless specifically noted otherwise, any sub agreement in excess of \$25,000 entered into as a result of this Agreement shall contain all the applicable provisions stipulated in this Agreement.

2.4 The Contractor shall pay its subcontractors within ten (10) calendar days from receipt of each payment made to the Contractor by the State.

2.5 Any substitution of subcontractors must be approved in writing by the Authority's Contract Manager in advance of assigning work to a substitute subcontractor.

[THE REMAINDER OF THIS PAGE IS INTENTIONALLY BLANK.]



Form R: Proposer Nondisclosure Agreement (Technical Drawings and Reports)

***California High-Speed Rail Authority
Track and Systems Construction Contract (TSCC)***

Nondisclosure Agreement for Technical Drawings and Reports

I, _____, hereby agree as follows:

I will maintain strict confidentiality and will not disclose information related to the technical drawings and reports made available by the California High-Speed Rail Authority (Authority), beyond the needs for developing a proposal for the **TSCC, RFP No.: HSR25-89**.

I further acknowledge that this information accessible through BOX is deemed Confidential Information and is the exclusive property of the Authority and to be used within the strict scope and needs of the TSCC.

As a result, I will not use the Confidential Information for research purposes, will not apply for or register any industrial or intellectual property rights in direct or indirect relation to the Confidential Information, nor claim any copyright or other intellectual property rights associated with the technical drawings and reports.

I hereby execute this Confidentiality Agreement and acknowledge that I may be subject to criminal, civil and/or financial penalties for breaching this Confidentiality Agreement.

Signature

Date

Printed Name

Printed Title

Representing

RFP No.: HSR25-89 TSCC ADDENDUM 8 04/01/2026



Form S: Past Performance Questionnaire

Instructions:

- A. All certifications shall be provided for each Equity Member, Lead Contractor, Lead Designer, and any Guarantor (each a “Covered Entity”).
- B. References to a Covered Entity include the relevant experience of such Covered Entity, as well as any Affiliate of such Covered Entity, and any entity to which it is a successor or assign (but only to the extent the experience is legally deemed to be that of the firm as a result of the relevant succession or assignment).
- C. The certifications in this Form S that are required in respect of Affiliates are limited to Affiliates that have engaged in business or investments in North America during the past 10 years.
- D. Covered Entities are not required to include responses that are restricted from disclosure under any applicable Law.

Questions:

- (1) Has the Covered Entity or any Affiliate (or any current officer, director or employee of either) been indicted or convicted of bid (e.g., fraud, bribery, collusion, conspiracy, antitrust, etc.) or other contract-related crimes or violations within the past ten (10) years (measured from the date of issuance of this RFP)?
If yes, please explain:

RFP No.: HSR25-89 TSCC ADDENDUM 8 04/01/2026



- (2) Has the Covered Entity or any Affiliate (or any current officer or director of either) been indicted or convicted of any other felony or serious misdemeanor within the past ten (10) years (measured from the date of issuance of this RFP)?

If yes, please explain:

- (3) Has the Covered Entity or any Affiliate ever sought protection through receivership or under any provision of any bankruptcy act within the past ten (10) years (measured from the date of issuance of this RFP)?

If yes, please explain:

RFP No.: HSR25-89 TSCC ADDENDUM 8 04/01/2026



- (4) Has the Covered Entity or any Affiliate ever been disqualified, removed, debarred or suspended from performing work for the federal government, any state or local government, or any foreign governmental entity within the past ten (10) years (measured from the date of issuance of this RFP)?

If yes, please explain:

- (5) Has the Covered Entity or any Affiliate ever been found liable in a civil suit or found guilty in a criminal action for making any false claim or other material misrepresentation to a public entity within the past ten (10) years (measured from the date of issuance of this RFP)?

If yes, please explain, including the result of the inquiry:

RFP No.: HSR25-89 TSCC ADDENDUM 8 04/01/2026



- (6) Has any project performed or managed by the Covered Entity or, to the knowledge of the undersigned, any Affiliate, involved repeated or multiple failures to comply with safety rules, regulations, or requirements within the past ten (10) years (measured from the date of issuance of this RFP)?

If yes, please identify the projects, provide an explanation of the circumstances, and provide owner contact information including telephone numbers and email addresses:

RFP No.: HSR25-89 TSCC ADDENDUM 8 04/01/2026



- (7) Has the Covered Entity or any Affiliate been found, adjudicated or determined by any federal or state court or agency (including, but not limited to, the Equal Employment Opportunity Commission, the Office of Federal Contract Compliance Programs and any applicable California governmental agency) to have violated any laws or Executive Orders relating to employment discrimination or affirmative action within the past ten (10) years (measured from the date of issuance of this RFP), including but not limited to Title VII of the Civil Rights Act of 1964, as amended (42 U.S.C. Sections 2000 et. seq.); the Equal Pay Act (29 U.S.C. Section 206(d)); and any applicable or similar California law?

If yes, please explain:

RFP No.: HSR25-89 TSCC ADDENDUM 8 04/01/2026



- (8) Has the Covered Entity or any Affiliate been found, adjudicated, or determined by any state court, state administrative agency, including, but not limited to, the California Office of Labor Commissioner, federal court or federal agency, to have violated or failed to comply with any law or regulation of the United States or any state within the past ten (10) years (measured from the date of issuance of this RFP) governing prevailing wages (including but not limited to payment for health and welfare, pension, vacation, travel time, subsistence, apprenticeship or other training, or other fringe benefits) or overtime compensation?

If yes, please explain:

RFP No.: HSR25-89 TSCC ADDENDUM 8 04/01/2026



- (9) With respect to each of Questions 1-8 above, if not previously answered or included in a prior response on this form, is any proceeding, claim, matter, suit, indictment, etc., currently pending against the Covered Entity or any Affiliate that could result in the firm being found liable, guilty or in violation of the matters referenced in Questions 1-8 above and/or subject to debarment, suspension, removal or disqualification by the federal government, any state or local government, or any foreign governmental entity?

If yes, please explain and submit the information requested as to such similar items set out in Questions 1-8 above

RFP No.: HSR25-89 TSCC ADDENDUM 8 04/01/2026



- (10) In the past five (5) years (measured from the date of issuance of this RFP), has there been any violation by the Covered Entity or any Affiliate of the Contractors' State License Law, as described in Chapter 9 (commencing with Section 7000) of Division 3 of the Business and Professions Code, including alleged violations of federal or state law regarding the payment of wages, benefits, apprenticeship requirements, or personal income tax withholding, or Federal Insurance Contribution Act (FICA) withholding requirements settled against the Covered Entity or any Affiliate?

If yes, please explain:

RFP No.: HSR25-89 TSCC ADDENDUM 8 04/01/2026



- (11) In the past five (5) years (measured from the date of issuance of this RFP), have there been any citations, assessed penalties or settlements against the Covered Entity or any Affiliate for any serious, willful or repeat violations of Part 1 (commencing with Section 6300) of Division 5 of the Labor Code or the federal Occupational Safety and Health Act of 1970 (Public Law 91-596)?
If yes, please explain:

RFP No.: HSR25-89 TSCC ADDENDUM 8 04/01/2026



- (12) In the past five (5) years (measured from the date of issuance of this RFP), has there been any instance where the Covered Entity or any Affiliate, or its owners, officers, or managing employees submitted a bid on a public works project, and were found to be nonresponsive or were found by an awarding body not to be a responsible bidder/proposer?

If yes, please provide details identifying the owner and an explanation of the basis for the owner's determination.

RFP No.: HSR25-89 TSCC ADDENDUM 8 04/01/2026



- (13) In the past five (5) years (measured from the date of issuance of this RFP), has there been any adverse claim, dispute, or lawsuit between the owner of a public works project (or any higher-tier contractor, project company, concessionaire, developer or the equivalent) and the Covered Entity or any Affiliate (including to the extent settled prior to completion of the proceeding) in which the claim, settlement, or judgment exceeded five hundred thousand dollars (\$500,000) (excluding matters that were processed under a customary change order process under the terms of a contract)?

If yes, please provide details identifying all such projects by owner and include owner's contact details, and all other information necessary to fully explain the circumstances surrounding the claim, dispute, lawsuit, or settlement, and the outcome.

RFP No.: HSR25-89 TSCC ADDENDUM 8 04/01/2026



- (14) In the past ten (10) years (measured from the date of issuance of this RFP), have there been change orders in excess of 20% of the contract value (at project award) on any contract between the owner and the Covered Entity or any Affiliate that were initiated by the Covered Entity or Affiliate (whether or not such change orders were processed under a customary process under the terms of a contract) for contracts in excess of one hundred million dollars (\$100,000,000) in value?

If yes, please provide details identifying all such projects by owner and include owner's contact details, the date of completion of the project, dollar amount of contractor-initiated changes and all other information necessary to fully explain these change orders:

RFP No.: HSR25-89 TSCC ADDENDUM 8 04/01/2026



- (15) In the past five (5) years (measured from the date of issuance of this RFP), has the Covered Entity or any Affiliate had liquidated damages assessed against it during or after completion of a contract in an amount in excess of two hundred-fifty thousand dollars (\$250,000)?

If yes, please provide details identifying all such projects by owner and include owner's contact details, the date of completion of the project, dollar amount of liquidated damages assessed, and all other information necessary to fully explain the rationale for project delays or others grounds for liquidated damages assessment:

RFP No.: HSR25-89 TSCC ADDENDUM 8 04/01/2026



- (16) In the past ten (10) years (measured from the date of issuance of this RFP), has a surety or any Affiliate completed a contract on the Covered Entity’s behalf or paid for completion, either because the Covered Entity or any Affiliate determined to terminate its involvement in a project for any reason, or was terminated by the project owner?

If yes, please provide details identifying all such projects by owner and include owner’s contact details, the date of termination, and all other information necessary to fully explain the relevant occurrences:

RFP No.: HSR25-89 TSCC ADDENDUM 8 04/01/2026



- (17) In the past five (5) years (measured from the date of issuance of this RFP), has the Covered Entity or any Affiliate been terminated, had an owner decline to enter into an implementation agreement (or its equivalent), or had an owner exercise an “off-ramp,” re-procure option, or enter into an implementation agreement with another entity (or equivalent circumstance) at the conclusion of the first phase of a progressive or other collaborative delivery due to failure to meet a price or schedule target, or otherwise fail to agree to the terms of such definitive agreement following a pre-development (or equivalent) period.

If yes, please provide details identifying all such projects by owner and include owner’s contact details, the date of initiation of the project, and all other information necessary to fully explain circumstances surrounding the failure to proceed:

RFP No.: HSR25-89 TSCC ADDENDUM 8 04/01/2026



- (18) In the past ten (10) years (measured from the date of issuance of this RFP), has a surety made payments on behalf of the Covered Entity of any Affiliate under any payment bond? *If yes, please provide details identifying all such projects by owner and include owner's contact details, and all other information necessary to fully explain the relevant occurrences:*

RFP No.: HSR25-89 TSCC ADDENDUM 8 04/01/2026



- (19) In the past ten (10) years (measured from the date of issuance of this RFP), has the Covered Entity or any Affiliate had a contract terminated for cause or convenience, or received a written waiver of another party’s right to terminate a contract for cause?

If yes, please provide details identifying all such projects by owner and include owner’s contact details, the date of termination or waiver, and all other information necessary to fully explain the relevant occurrences:

RFP No.: HSR25-89 TSCC ADDENDUM 8 04/01/2026



- (20) In the past ten (10) years (measured from the date of issuance of this RFP), has there been any instance involving any projects or contracts with a value in excess of one hundred million dollars (\$100,000,000) in relation to which the Covered Entity or any Affiliate was determined by a court of law or in an arbitration proceeding, a dispute review board proceeding, or any other dispute resolution proceeding, or otherwise acknowledged in writing to be liable for a material breach of contract?

If yes, please provide details identifying all such projects by owner and include owner's contact details, and all other information necessary to fully explain the relevant occurrences:

RFP No.: HSR25-89 TSCC ADDENDUM 8 04/01/2026



(21) In the past five (5) years (measured from the date of issuance of this RFP), has a surety or any Affiliate terminated a major subcontractor or dissolved a joint venture following award of a public works project but prior to its completion?

If yes, please provide details indicating the project(s), the major subcontractor or joint venture that was terminated and describe the basis for this action:

RFP No.: HSR25-89 TSCC ADDENDUM 8 04/01/2026



- (22) In the past five (5) years (measured from the date of issuance of this RFP), has the Covered Entity or any Affiliate been issued any notice of default or notice to cure under by the owner of a public works project?

If yes, please provide details identifying all such projects by owner and include owner's contact details, the date of completion of the project, and all other information necessary to fully explain circumstances surrounding the default, any cure, and the outcome:

RFP No.: HSR25-89 TSCC ADDENDUM 8 04/01/2026



- (23) In the past five (5) years (measured from the date of issuance of this RFP), has the Covered Entity or any Affiliate removed a key personnel from a project, or had a key personnel removed by the owner of a public works project, for performance issues?

If yes, please explain:

RFP No.: HSR25-89 TSCC ADDENDUM 8 04/01/2026



- (24) In the past five (5) years (measured from the date of issuance of this RFP), has the Covered Entity had any license, credential, or registration revoked or suspended?
If yes, please provide specific details including date(s), reason(s), for revocation or suspension, whether same was reinstated, and any conditions thereto:

Signature

Date

Printed Name

Printed Title

Representing

RFP No.: HSR25-89 TSCC ADDENDUM 8 04/01/2026



Cert. 1: Debarment, Suspension, Ineligibility, and Voluntary Exclusion Certification

I, _____ hereby certify that
(Name of Entity’s Official Representative)

(Name of Entity)

- Is not presently debarred, suspended, proposed for debarment, declared ineligible, or voluntarily excluded from participation by any State or federal department or agency;
- Has not within a three-year period preceding this Proposal been convicted of or had a civil judgment rendered against them for commission of fraud or a criminal offense in connection with obtaining, attempting to obtain, or performing a public (federal, State or local) transaction or contract under a public transaction; violation of federal or State antitrust statutes or commission of embezzlement, theft, forgery, bribery, falsification or destruction of records, making false statements, or receiving stolen property;
- Is not presently indicted for or otherwise criminally or civilly charged by a governmental entity (federal, State, or local) with commission of any of the offenses enumerated in Paragraph 2 of this certification;
- Has not within a five-year period preceding this Proposal in the preceding five years, been convicted of violating a State or federal law respecting the employment of undocumented aliens; and
- Has not within a three-year period preceding this proposal had one or more public transactions (federal, State, or local) terminated for cause or default.

If the Proposer or any Equity Member or Subcontractor is unable to certify to any of the statements in this certification, such prospective Proposer, Equity Member or Subcontractor shall attach an explanation to this certification.

**Organization Name,
Address, and Telephone**

Signature of Official Representative

Printed Name

Title

RFP No.: HSR25-89 TSCC ADDENDUM 8 04/01/2026



Cert. 2: Non-Collusion Affidavit

The undersigned declares: I am the

_____ of _____,
(Position / Title) (Company)

The party making the foregoing Proposal, and that the Proposal is:

- NOT made in the interest of, or on behalf of, any undisclosed person, partnership, company, association, organization, or corporation
- Genuine and NOT collusive or a sham.

That the Proposer has NOT directly or indirectly induced or solicited any other Proposer to:

- Put in a false or sham Proposal; and
- Colluded, conspired, connived, or agreed with any Proposer or anyone else to put in a sham Proposal or that anyone shall refrain from bidding.

That the Proposer has NOT, in any manner directly or indirectly, sought by agreement, communication or conference with anyone to:

- Fix the Price Proposal of the Proposer or any other Proposer, or
- Fix any overhead, profit, or cost element of the Price Proposal, or of that of any other Proposer, or
- Secure any advantage against the public body awarding the contract or anyone interested in the proposed contract.

That all statements contained in the Proposal are true.

The Proposer has not and will not, directly or indirectly, for the purposes of effectuating a collusive or sham Price Proposal, submitted his or her Price Proposal or any breakdown thereof, or the contents thereof, or divulged information or data relative thereto, for payment to any corporation, partnership, company, association, organization, bid depository, or any member or agent thereof.

I declare under penalty of perjury under the laws of the State of California that the foregoing is true and correct and that is declaration is executed on _____ [date], at _____ [city], _____ [state].

Signature of Official Representative

Printed Name

Title

RFP No.: HSR25-89 TSCC ADDENDUM 8 04/01/2026



Cert. 3: Organizational Conflicts of Interest Affidavit

My name is _____ I am the _____
(Entity’s Official Representative Printed Name) (Title)

of _____
(Entity Name)

I am of sound mind, capable of making this affidavit — over 21 years of age, and personally acquainted with the facts herein stated. I am duly authorized to make this affidavit and do hereby on oath state the following:

I am aware that the Conflict of Interest Policy, of the AUTHORITY prescribes responsibilities, general rules, and procedures for identifying, evaluating, and resolving organizational conflicts of interest.

I am aware that section II.9 of the AUTHORITY’s Conflict of Interest Policy contains the following definition:

An Organizational Conflict of Interest means a circumstance arising out of a Contractor’s existing or past activities, business or financial interests, familial relationships, contractual relationships, and/or organizational structure (i.e., parent entities, subsidiaries, Affiliates, etc.) that results in (i) impairment or potential impairment of a Contractor’s ability to render impartial assistance or advice to the Authority, or of its objectivity in performing work for Authority; (ii) an unfair competitive advantage for any Contractor bidding or proposing on an Authority procurement; or (iii) a perception or appearance of impropriety with respect to any of the Authority’s procurements or contracts, or a perception or appearance of unfair competitive advantage with respect to a procurement by the Authority (regardless of whether any such perception is accurate).

1. _____, its officers, employees, and agents, are subject
(Entity Name)
to the provisions of the, AUTHORITY’s Conflict of Interest Policy.

A diligent search of the relationships and interests of _____
(Entity Name)

its officers, employees, and agents, has been conducted to determine whether any Organizational Conflict of Interest may exist relating to or resulting from Request for Proposals No. 25-89 or any contract that may be entered as a result of this Request for Proposals.

2. _____, its officers, employees, and agents, do not



(Entity Name)

have an Organizational Conflict of Interest under the AUTHORITY's Conflict of Interest Policy. Where there is any question as to a possible Organizational Conflict of Interest, all necessary and applicable information has been provided in Form E submitted as part of this Proposal.

3. If an Organizational Conflict of Interest is discovered at any time in the future,

_____ will submit an Organizational Conflicts of
(Entity Name)

Interest Disclosure Statement (Form H), notifying the AUTHORITY of the existence and nature of the conflict within three (3) Working Days following the discovery of the Organizational Conflict of Interest.

I declare under penalty of perjury under the laws of the State of California that the foregoing is true and correct and that is declaration is executed on _____ [date], at _____ [city], _____ [state].

Signature of Official Representative

Printed Name

Title

RFP No.: HSR25-89 TSCC ADDENDUM 8 04/01/2026



Cert. 4: Equal Employment Opportunity Certification

The undersigned certifies on behalf of _____ that:
(Name of entity making certification)

Check one of the following boxes:

- It has developed and has on file at each establishment affirmative action programs pursuant to 41 C.F.R. Part 60-2 (Affirmative Action Programs).
- It is not subject to the requirements to develop an affirmative action program under 41 C.F.R. Part 60-2 (Affirmative Action Programs).

Check one of the following boxes:

- It has not participated in a previous contract or subcontract subject to the equal opportunity clause described in Executive Orders 10925, 11114 or 11246.
- It has participated in a previous contract or subcontract subject to the equal opportunity clause described in Executive Orders 10925, 11114, or 11246, and, where required, it has filed with the Joint Reporting Committee, the Director of the Office of Federal Contract Compliance, a Federal Government contracting or administering agency, or the former President’s Committee on Equal Employment Opportunity, all reports due under the applicable filing requirements.

Offering Organization Name, Address, and Telephone

Signature of Official Representative

Printed Name

Title

RFP No.: HSR25-89 TSCC ADDENDUM 8 04/01/2026



Cert. 5: Non-Discrimination Certification

In accordance with title VI of the Civil Rights Act, as amended; 42 U.S.C. section 2000d, the Proposer agrees that it will not discriminate against any individual because of race, color, national origin, or sex in any activities leading up to or in performance of the Contract.

**Offering Organization Name,
Address, and Telephone**

Signature of Official Representative

Printed Name

Title

RFP No.: HSR25-89 TSCC ADDENDUM 8 04/01/2026



Cert. 6: Certification Regarding Lobbying

The undersigned certifies, to the best of his or her knowledge and belief, that the following are true:

- No federal appropriated funds have been or will be paid, by or on behalf of the undersigned, to any person for influencing or attempting to influence an officer or employee of any agency, a member of Congress, an officer or employee of Congress in connection with the awarding of any federal contract, the making of any federal grant, the making of any federal loan, the entering into of any cooperative agreement, and the extension, continuation, renewal, amendment, or modification of any federal contract, grant, loan, or cooperative agreement.
- If any funds other than federal appropriated funds have been paid or will be paid to any person for influencing or attempting to influence an officer or employee of any agency, a member of Congress, an officer or employee of Congress, or an employee of a member of Congress in connection with this federal contract, grant, loan, or cooperative agreement, the undersigned shall complete and submit Standard Form-LLL, Disclosure Form to Report Lobbying, in accordance with its instructions.
- The undersigned shall require that the language of this certification be included in the award documents for all sub-awards at all tiers (including subcontracts, sub-grants, and contracts under grants, loans, and cooperative agreements), and that all sub-recipients shall certify and disclose accordingly.

This certification is a material representation of fact upon which reliance is placed when this transaction was made or entered into. Submission of this certification is a prerequisite for making or entering into this transaction imposed by 31 U.S.C. section 1352. Any person who fails to file the required certification shall be subject to a civil penalty of not less than \$10,000 and not more than \$100,000 for each such failure.

**Offering Organization Name,
Address, and Telephone**

Signature of Official Representative

Printed Name

Title

RFP No.: HSR25-89 TSCC ADDENDUM 8 04/01/2026



Cert. 7: Drug Free Workplace Program Certification

(This certification applies to construction work sites only.)

By submission of an offer, the Proposer certifies and agrees that, with respect to the Proposer and all employees of the Proposer to be utilized in the performance of any contract resulting from this solicitation, it will establish a drug-free workplace program that complies with the provisions of the Drug-Free Workplace Program clause of Article 46.5 of the General Provisions.

Failure of the Proposer to have a drug-free workplace program that complies with this certification and the clause in the General Provisions, which is available for Authority review and approval as part of the Authority’s pre-award responsibility survey, will be deemed a lack of responsibility rendering the Proposer ineligible for award.

**Offering Organization Name,
Address, and Telephone**

Signature of Official Representative

Printed Name

Title

RFP No.: HSR25-89 TSCC ADDENDUM 8 04/01/2026



Cert. 8: Buy America Compliance or Non-Compliance Certifications

The Proposer/Contractor shall comply with 49 U.S.C. section 22905(a), which provides that Federal funds may not be obligated unless steel, iron, and manufactured products used in FRA-funded projects are produced in the United States, unless a waiver has been granted.

Certificate of Compliance with 49 U.S.C. Section 22905(a)

- The Proposer/Contractor hereby certifies that it will comply with the FRA Buy America requirements of 49 U.S.C. section 22905(a)(1).

Date: _____

Signature: _____

Printed Name: _____

Company Name: _____

Title: _____

Certificate of Non-Compliance with 49 U.S.C. Section 22905(a)²

- The Proposer/Contractor hereby certifies that it cannot comply with the requirements of 49 U.S.C. section 22905(a)(1) but it may meet the requirements for a waiver pursuant to 49 U.S.C. section 22905(a)(2) and has provided the Authority with a written Buy America waiver justification.

Date: _____

Signature: _____

Printed Name: _____

Company Name: _____

Title: _____

² Note: The written justification, as required by the Certificate of Non-Compliance with 49 U.S.C. section 22905 (a)(1) above, shall be provided as an attachment to this Certification form.

RFP No.: HSR25-89 TSCC ADDENDUM 8 04/01/2026



Cert. 9: Iran Contracting Certification

Section 2200 et seq. of the California Public Contract Code prohibits a person from submitting a proposal for a contract with a public entity for goods and services of \$1,000,000 or more if that person is identified on a list created by the Department of General Services (DGS) pursuant to section 2203(b) of the California Public Contract Code. The list will include persons providing goods or services of \$20,000,000 or more in the energy sector of Iran and financial institutions that extend \$20,000,000 or more in credit to a person that will use the credit to provide goods or services in the energy sector in Iran. DGS is required to provide notification to each person that it intends to include on the list at least 90 days before adding the person to the list.

In accordance with section 2204 of the California Public Contract Code, the undersigned hereby certifies that:

- It is not identified on a list created pursuant to section 2203(b) of the California Public Contract Code as a person engaging in investment activities in Iran described in section 2202.5(a), or as a person described in section 2202.5(b), as applicable; or
- It is on such a list but has received permission pursuant to section 2203(c) or (d) to submit a bid or proposal in response to this RFP HSR25-89] of the California High-Speed Rail Program.

Providing a false certification may result in civil penalties and sanctions.

**Offering Organization Name,
Address, and Telephone**

Signature of Official Representative

Printed Name

Title

RFP No.: HSR25-89 TSCC ADDENDUM 8 04/01/2026



Cert. 10: Darfur Contracting Act Certification

Pursuant to Public Contract Code section 10478, if a Proposer currently or within the previous three (3) years has had business activities or other operations outside of the United States, it must certify that it is not a scrutinized company as defined in Public Contract Code section 10476.

Therefore, to be eligible to submit a bid or proposal, please complete only one of the following three paragraphs (via initials for Paragraph No. 1 or Paragraph No. 2, or via initials and certification for Paragraph No. 3):

1. _____ We do not currently have, or we have not had within the previous three
 Initials years, business activities or other operations outside of the United States.

OR

2. _____ We are a scrutinized company as defined in Public Contract Code Section
 Initials 10476, but we have received written permission from the Department of General Services (DGS) to submit a bid or proposal pursuant to Public Contract Code section 10477(b). A copy of the written permission from DGS is included with our bid or proposal.

OR

3. _____ We currently have, or we have had within the previous three years,
 Initials business activities or other operations outside of the United States, but we certify below that we are not a scrutinized company below as defined in Public Contract Code section 10476.

Certification for Paragraph No. 3

I, the official named below, CERTIFY UNDER PENALTY OF PERJURY that I am duly authorized to legally bind the prospective Proposer to the clause listed above in Paragraph No. 3. This certification is made under the laws of the State of California.

Entity Name (Printed)		Federal ID Number
By (Official Representative Signature)		
Printed Name and Title of Person Signing		
Date Executed	Executed in the County and State of	

RFP No.: HSR25-89 TSCC ADDENDUM 8 04/01/2026



Cert. 11: Certification Regarding Miscellaneous State Requirements

I, the official named below, CERTIFY UNDER PENALTY OF PERJURY that I am duly authorized to legally bind the prospective Contractor to the clause(s) listed below. This certification is made under the laws of the State of California.

Entity Name (Printed)		Federal ID Number
By (Official Representative Signature)		
Printed Name and Title of Person Signing		
Date Executed	Executed in the County and State of	

Contractor Certification Clauses:

- **Statement of Compliance** - Contractor has, unless exempted, complied with the nondiscrimination program requirements. (Gov. Code section 12990 (a-f) and CCR, title 2, section 8103) (Not applicable to public entities.)
- **National Labor Relations Board Certification** - Contractor certifies that no more than one (1) final unappealable finding of contempt of court by a Federal court has been issued against Contractor within the immediately preceding two-year period because of Contractor's failure to comply with an order of a Federal court, which orders Contractor to comply with an order of the National Labor Relations Board. (Pub. Contract Code section 10296) (Not applicable to public entities.)
- **Expatriate Corporations** - Contractor hereby declares that it is not an expatriate corporation or subsidiary of an expatriate corporation within the meaning of Public Contract Code section 10286 and 10286.1, and is eligible to contract with the State of California.
- **Domestic Partners** - For contracts over \$100,000 executed or amended after January 1, 2007, the contractor certifies that contractor is in compliance with Public Contract Code section 10295.3.

RFP No.: HSR25-89 TSCC ADDENDUM 8 04/01/2026



Cert. 12: Proposer’s Project Small Business Goal Commitment Affidavit**AFFIDAVIT**

 (Name)

 is the Official Representative of

(Proposer’s Name)

the Proposer submitting the foregoing Proposal.

(If the Proposer has not yet been formed, modify this form as appropriate to include the names of all of the Principal Participants and to indicate that the Official Representative is signing the form on behalf of all of the Principal Participants.)

The Proposer has carefully examined all documents that form this Request for Proposal and is aware that California High-Speed Rail Authority (Authority) has established a Small Business goal of 25 percent for Small Business utilization, inclusive of a 3 percent goal for Microbusiness utilization, on the state portion of the contract; a separate 10 percent goal for Disadvantaged Business Enterprise utilization, which will be applied across the total contract value; and a separate 3 percent goal for Disabled Veteran Business Enterprise utilization, which will be applied across the total contract value. These goals are in conformance with Executive Order S-02-06, title VI of the Civil Rights Act of 1964, and related statutes and Best Practices of title VI, Government Code §§ 4532-4535, 11148.5, 12098.4, and 14835-14847, and Military and Veterans Code section 999, as set forth in the Authority’s HSR Small Business Program Plan.

If awarded the Contract, the Proposer commits to use best efforts to meet the 25 percent Small Business goal, inclusive of a 3 percent Microbusiness goal, as well as the separate 3 percent DVBE goal, as described above. The Proposer also commits to use good faith efforts to reach the 10 percent race-neutral goal for DBE participation. The Proposer commits to submit all required reports and information in support of its efforts to meet the Authority’s High-Speed Rail Small Business Program Plan goals.

[SIGNATURE PAGE TO FOLLOW]



I declare under penalty of perjury under the laws of the State of California that the foregoing is true and correct and that is declaration is executed on _____ [date], at _____ [city], _____ [state].

Signature of Official Representative

Printed Name

Title

RFP No.: HSR25-89 TSCC ADDENDUM 8 04/01/2026



Cert. 13: California Civil Rights Laws Certification

Pursuant to Public Contract Code section 2010, if a Proposer executes or renews a contract over \$100,000 on or after January 1, 2017, the bidder or proposer hereby certifies compliance with the following:

California Civil Rights Laws: For contracts over \$100,000 executed or renewed after January 1, 2017, the Proposer certifies compliance with the Unruh Civil Rights Act (section 51 of the Civil Code) and the Fair Employment and Housing Act (section 12960 of the Government Code); and,

Employer Discriminatory Policies: For contracts over \$100,000 executed or renewed after January 1, 2017, if a Contractor has an internal policy against a sovereign nation or peoples recognized by the United States government, the Proposer certifies that such policies are not used in violation of the Unruh Civil Rights Act (section 51 of the Civil Code) or the Fair Employment and Housing Act (section 12960 of the Government Code).

I, the official named below, CERTIFY UNDER PENALTY OF PERJURY that I am duly authorized to legally bind the Proposer to the clause listed above. This certification is made under the laws of the State of California.

Title of Company Official	
By (Authorized Signature)	
Printed Name and Title	
Date Executed	Executed in the County and State of

RFP No.: HSR25-89 TSCC ADDENDUM 8 04/01/2026



Cert. 14: CCC 04/2017 and STD 204

Please complete and submit the [CCC 04/2017 form](#) located the Department of General Services website (www.dgs.ca.gov/OLS/Resources/Page-Content/Office-of-Legal-Services-Resources-List-Folder/Standard-Contract-Language).

Also complete and submit the [STD 204 form](#) located the Department of General Service website (www.documents.dgs.ca.gov/dgs/fmc/pdf/std204.pdf).



Cert. 15: Generative Artificial Intelligence Disclosure

Please notify the State in writing if Proposer: (1) intends to provide GenAI as a deliverable to the State; or (2), intends to utilize GenAI, including GenAI from third parties, to complete all or a portion of any deliverable that materially impacts: (i) functionality of a State system, (ii) risk to the State, or (iii) Contract performance.

RFP No.: HSR25-89 TSCC ADDENDUM 8 04/01/2026



Cert. 16: Escrowed Proposal Documents Certification

The undersigned does hereby certify that they have personal knowledge of the preparation of the proposal cost and pricing documents, that they have examined the documents, and that, to the best of their knowledge, the documentation is complete and accurate and otherwise complies with the Authority’s “Escrowed Proposal Documentation” clause relating to this solicitation. entity certifies that it lawfully owns an irrevocable, perpetual, fully paid-up right and license to use, exploit, manufacture, distribute, copy, adapt and display all Intellectual Property incorporated into the Proposal and to grant to Authority the rights related to such Intellectual Property described in the Contract.

**Offering Organization Name,
Address, and Telephone**

Signature of Certifying Representative

Printed Name

Title

RFP No.: HSR25-89 TSCC ADDENDUM 8 04/01/2026

